

# OWNER'S MANUAL



# DKW-Duo

Dual Wireless Microphone System



# Contents

Introduction .....	2
System Features .....	2
Operation.....	3
Specifications .....	6
Service Information .....	6
Warranty .....	7

## Introduction

Thank you for choosing the Nady DKW-Duo dual wireless microphone system, we know you will be very pleased with its performance and features. The Nady DKW-Duo is the perfect entry-level professional wireless, delivering clear, transparent audio for a variety of singing and speech applications at a breakthrough new low price.

## System Features

### Receiver

- All the advantages and freedom of one or two channels of wireless operation without cumbersome cords
- Easy to use—simply plug into your audio mixer or amplifier instead of your wired lavalier/lapel microphone
- Use with single WLT transmitter or with two transmitters for simultaneous dual operation of both receivers
- Excellent high fidelity audio—perfect for public speaking, karaoke/recreational singers, DJ's, and many other applications
- 150+ feet typical operating range—up to 300+ feet line-of-sight
- High-band VHF (170-216 MHz) operation for interference-free performance
- Advanced audio processing circuitry for a wide dynamic range (no overloading for loud inputs or background hiss during quiet use)
- Complete controls and connections for professional operation include front panel Power On/Off switch, Ch. 1/Ch. 2 output volume controls, Power On LED, Ch. 1/Ch. 2 transmitter on LED indicators

- Back panel 1/4" audio output jack and DC power input jack for supplied AC/DC adaptor
- Dual retractable Ch.1/Ch. 2 antennas
- Special added circuitry eliminates transmitter On/Off "pop" noise

### WLT Bodypack Transmitter

- Supplied with LM-140 omnidirectional lavalier/lapel microphone
- Off/Standby/On switch allows convenient audio muting with the transmitter on
- Low battery LED indicator flashes once for Unit On; lights steady for low-battery alert
- Locking 3.5mm mini-jack provides secure connection for removable microphone cable
- Easily accessible input level adjust control for optimum sound

# Operation

## Receiver

1. Plug the AC/DC adapter (provided) into the **9VDC INPUT JACK (3)** on the back of the receiver. Then plug the power supply into an AC outlet. Switch the **POWER (1)** to the "On" position. The **POWER ON LED (2)** will now light and the receiver is operational.

2. Rotate and extend **ANTENNA (4)** fully, angled at 60° position as shown.

3. The **1/4" AUDIO OUTPUT JACK (5)** provides a fixed, unbalanced MIC level audio output for connection to your mixer with the 1/4" to 1/4" cord supplied. As when making any connection, make sure the mixing board's volume is at the minimum level before plugging in the receiver to avoid possible sound system damage. Use the **VOLUME CONTROLS (6)** to adjust the volume.

*Note: this output is the sum of the signals received by both the internal receivers (CH 1 + CH 2). Use the CH 1 & CH 2 VOLUME CONTROLS (6) to adjust the individual relative channel volumes.*

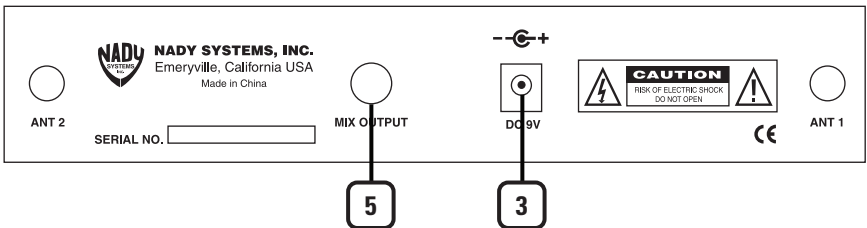
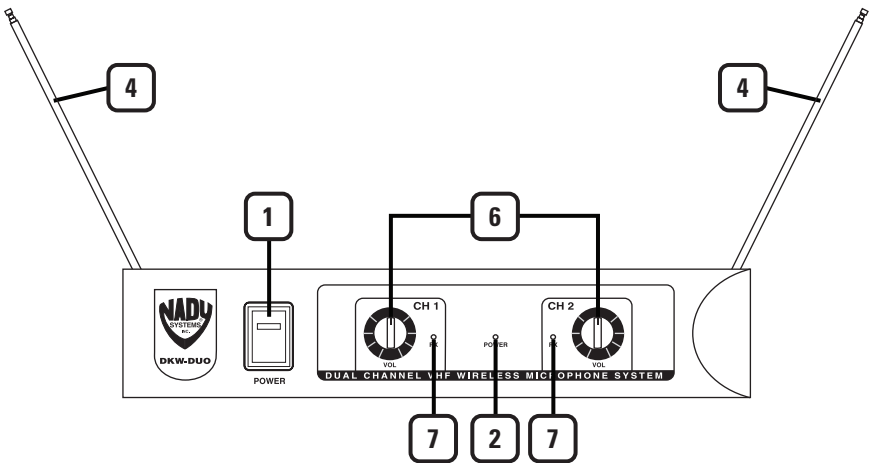

## WLT Bodypack Transmitter

1. Snap open the **BATTERY COMPARTMENT (12)** and insert a fresh **9V BATTERY (13)**, observing the correct polarity. Close the compartment.

2. The WLT is provided with a **3.5 mm LOCKING JACK (14)** for connecting the microphone. Plug in the supplied **LAVALIER/LAPEL MICROPHONE (15)**. To secure the connection, turn the metal slip ring on the plug clockwise to thread it on to the jack. To unplug, reverse the process. Slip the transmitter into a pocket or clip on to your clothes. To use the lavalier mic, attach it at chest level. Do not place too close to the mouth—a distance of about six inches usually works best. To use the headworn mic, place it on the head and adjust the mic boom so that the mic is about one inch to the side of the front of the mouth.

*(Note: The lavalier/lapel mic wire is also the transmit antenna, and rolling up or shortening the wire may reduce the effective operating range. Extend the wire fully during use, and keep it as straight as possible.)*

3. Turn on the WLT by sliding the **OFF/STANDBY/ON SWITCH (16)** to the Standby position (transmitter on, audio muted) or the On position (transmitter and audio both on). The **BATTERY INDICATOR LED (17)** will give a single quick flash, indicating usable battery strength. In the case of a dead or low battery, the LED either will not go on at all or will stay on continuously, indicating that the battery should be replaced with a fresh one.

4. The microphone is now ready to use. When ready to speak, slide the transmitter switch to the On position and adjust the volume of the receiver as per the previous *Receiver Operation* section. For optimum performance, an **INPUT LEVEL CONTROL (18)** is provided on the top panel of the WLT. Adjust the gain by turning the control with a small slot head screwdriver. It is recommended that this control be turned to maximum gain.

*(Note: Observe care in selecting P.A. volume, transmitter location and speaker placement so that acoustic feedback (howling and screeching) will be avoided. Omnidirectional mics pick up sound equally from all directions and are prone to feedback if not used carefully. Mics that are farther from the sound source, such as lavaliers, require more acoustic gain and thus are prone to feedback.)*

*(Note: Microphone elements can easily be destroyed by the buildup of salts and minerals from perspiration and saliva. It is good practice to put a windscreen on the mic element at all times to protect it.)*

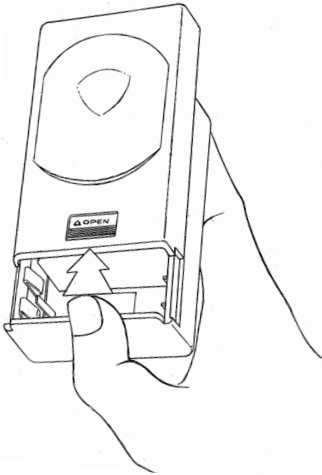
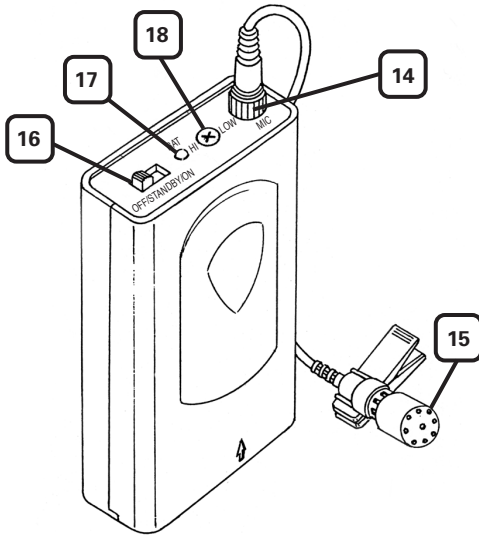

Opening Battery Compartment

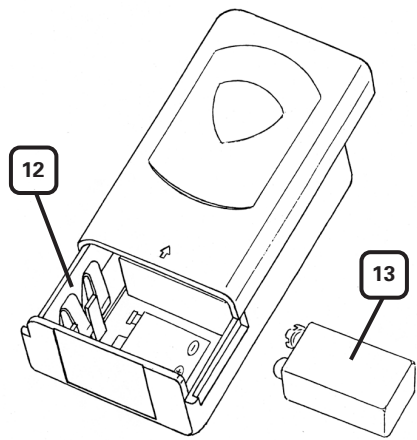

# Specifications

## OVERALL SYSTEM PERFORMANCE

<b>Frequency Response</b>	80-14,000 Hz, +/-3dB
<b>Dynamic Range</b>	95dB
<b>Total Harmonic Distortion</b>	<0.7%
<b>RF Carrier Frequency Range</b>	170-216 MHz
<b>Frequency Stability</b>	+/- 0.005%, crystal controlled
<b>Modulation</b>	FM (F3E), +/-15KHz max.
<b>Operating Range</b>	150 ft. typical—up to 300+ ft. line-of-sight

## TRANSMITTERS

<b>Audio Input</b>	3.5mm mono locking jack for connecting to omnidirectional lavalier/lapel mic, with phantom power
<b>Controls</b>	Off/Standby/On switch, Input Level adjust
<b>LED Indicator</b>	Unit On (single flash), Low-Battery Alert (steady)
<b>RF Power Out</b>	50mW (Max. allowed by FCC)
<b>Harmonic &amp; Spurious Emissions</b>	> -40dB
<b>Battery</b>	9V Alkaline
<b>Battery Life</b>	Up to 15 hours
<b>Dimensions</b>	4.1 x 2.4 x 0.8 in. (10.4 x 6.1 x 2.0 cm.)
<b>Weight (w/o battery)</b>	3.6 oz. (101 g.)

## RECEIVER

<b>Controls</b>	Power On/Off
<b>Connectors</b>	1/4" unbalanced audio out jack, 2.1mm barrel-type DC input jack
<b>LED Indicator</b>	Power On, Transmitter RF (CH A & CH B)
<b>Dimensions</b>	8.2 x 5.3 x 1.75 in. (20.8 x 13.5 x 4.4 cm.)
<b>Weight</b>	16.1 oz. (451 g.)
<b>Power Requirements</b>	9V @ 120mA, nominal, AC/DC adapter supplied
<b>Antennas</b>	Dual 15 in. (38 cm.) collapsible

*Specifications subject to change for product improvement purposes*

## Service Information

**In the U.S.** If you are experiencing operational problems with your system, please refer to the Support page at [www.nady.com](http://www.nady.com) for assistance. Should your wireless system require service, please contact the Nady Service Department at (510) 652-2411 to obtain a Return Authorization (R/A) Number and service quote (if out of warranty). Make sure the R/A Number is clearly marked on the outside of the package that you are returning.

If your unit is out of warranty, please enclose a cashier's check or money order (or pay by credit card) per instructions by the Nady Service Department. Ship your unit prepaid to: Nady Systems, Service Department, 6701 Shellmound Street, Emeryville, CA 94608. Include a brief description of the problem you are experiencing. For service of a unit under warranty, please follow the instructions in the following section.

**Outside the U.S.** For service or warranty matters please contact the Nady distributor in your country through the dealer/store from which you purchased this product.

**Do not attempt to service this unit yourself as it can be dangerous and will also void the warranty.**

# 90-Days Limited Warranty

Nady Systems, Inc. warrants to the original consumer purchaser (U.S.A. only) that the unit is free from any defects in material or workmanship for a period of 90 days from the date of original retail purchase. If any such defect is discovered within the warranty period, Nady Systems, Inc. will repair or replace the unit free of charge, subject to verification of the defect or malfunction upon return to Nady Systems. Please do not return your Nady product to the store where it was purchased as Nady Systems handles your warranty service directly. Communication with our Service Department is the most efficient means of servicing your unit and we are dedicated to keeping you a satisfied customer.

To the extent permitted by law, any applicable implied warranties, including warranties of merchantability and fitness are hereby limited to 90 days from the date of purchase. Consequential or incidental damages resulting from a breach of any applicable express or implied warranties are hereby excluded. This warranty is in lieu of all other agreements and warranties, general or special, express or implied and no representative or person including a Nady dealer, agent, or employee is authorized to assume for us any other liability in connection with the sale or use of this Nady Systems' product.

Whereas some states do not allow limitations on how long implied warranties last, and do not allow exclusion of incidental or consequential damages, the above limitations and exclusions may not apply to you. This warranty gives you specific legal rights and you may also have other rights which may vary from state to state.

## **This warranty is subject to the following conditions:**

- 1) This system must have been purchased from an authorized Nady dealer and all warranty service must be performed by Nady's service department. Any service not performed by Nady will automatically void this warranty.
- 2) Items not covered: physical damage resulting from improper handling of the unit in transit from the factory by the shipper (Nady Systems is not responsible for such damage and all such claims must be made against the shipping company by the consignee); defects caused by normal wear of the product (expendable parts are typically connectors, cables, potentiometers, switches and similar components); damage or defects caused by abuse, neglect, accident, failure to connect or operate the unit in any way that does not comply with applicable technical or safety regulations, or improper repair, excessive heat or humidity, alteration or unreasonable use of the unit, causing cracks, broken cases/housings or parts; damage caused by leaking batteries; finish or appearance items; items damaged in shipment en route to Nady Systems, Inc. for repair. The warranty is null and void if any Nady serial number has been removed or defaced.

## **How To Obtain Service:**

- 1) If factory service is required, please contact our Service Department at (510) 652-2411 for a return authorization (R/A) number. Make sure the R/A number is clearly marked on the outside of your package. (Please note: if an R/A number is not included, our Shipping Department cannot accept your package.)
- 2) Send the unit back to Nady Systems, 6701 Shellmound Street, Emeryville, CA, 94608, freight pre-paid. You must include proof of date and place of purchase (i.e., photocopy of your bill of sale) or Nady cannot be responsible for repair or replacement. Nady Systems, Inc. will not repair, nor be held responsible, for any units returned without proper identification, return address, and R/A number clearly marked on the package.
- 3) Per the above, Nady will perform all warranty service and return the unit to you at no charge. Nady Systems will inform the buyer if product sent in does not meet the terms of this warranty and will provide a quote for fixing the unit and/or shipping it back exclusively at the buyer's expense.



6701 Shellmound Street | Emeryville, CA USA 94608  
T 510.652.2411 | F 510.652.5075 | [www.nady.com](http://www.nady.com)