

OWNER'S MANUAL



MGT-16

16-Channel Mini UHF
Wireless Instrument System



Contents

Introduction	2
Using this Manual.....	2
System Features	3
Quick User Controls Guide.....	4
System Operation	7
MGT-16 Wireless Instrument Receiver	7
MT-16A/R Instrument Transmitter.....	9
Specifications	11
Cautions and Troubleshooting	12
Miscellaneous Tips	13
MGT-16 DIP-Switch Frequency Selection Chart.....	14
Accessories	14
Service Information	14
Warranty.....	15

Introduction

Thank you for choosing the Nady MGT-16 wireless system, we know you will be very pleased with its performance and features. The Nady MGT-16 is a 16-channel ultra compact UHF wireless system designed for guitar and bass. The MGT-16 has 16 selectable frequencies, up to 250' operating range, and infrared ASC™ Auto-Sync Channel transfer for quick, convenient setup. The stomp box size receiver can be placed anywhere you choose—even on stage next to your effects pedals. The miniature, lightweight MT-16A or MT-16R transmitter plugs directly into any guitar or bass, even into a portable keyboard output jack.

Using This Manual

This booklet provides information regarding the use of the MGT-16 Wireless Instrument System and includes a description of features and a step-by-step guide to operation of the unit. This manual should answer any questions you may have about the operation and servicing of your MGT-16.

System Features

MGT-16 System Features

- UHF wireless system for guitar/bass
- 16 user-selectable PLL frequencies for interference-free operation
- Up to 250' operating range, line-of-sight
- Infrared ASC™ Auto-Sync Channel transfer from receiver to transmitter for instant setup
- Battery operated receiver and transmitter

MGT-16 Receiver

- Compact, portable, “pedal style” receiver
- Dual ¼ wave antennas
- Infrared sync with transmitter for instant setup
- Unbalanced ¼” line out jack
- Power On/Off/Mute switch; Volume Control; LED indicators for Power On, Low Battery, and RF Reception; DIP-switch channel selection with IR sync to transmitter
- Powered by DC adapter (included) or two AA alkaline batteries for portability (up to 8 hours battery life)

MT-16A & MT-16R Transmitters

- Choice of two transmitter housings— MT-16A with 30° angled ¼” plug for use with either recessed or surface mounted jacks, or MT-16R with 90° angled ¼” plug for surface mounted jacks only
- Up to eight hours of battery life from a single AAA alkaline or NiMH rechargeable battery
- Infrared channel sync with receiver for instant setup
- Power On/Off switch; Power/Low Battery LED indicators; IR Sync LED; Input level attenuation switch; Internal audio level control trim-pot
- External flexible antenna

Quick User Controls Guide

MGT-16 Instrument Receiver

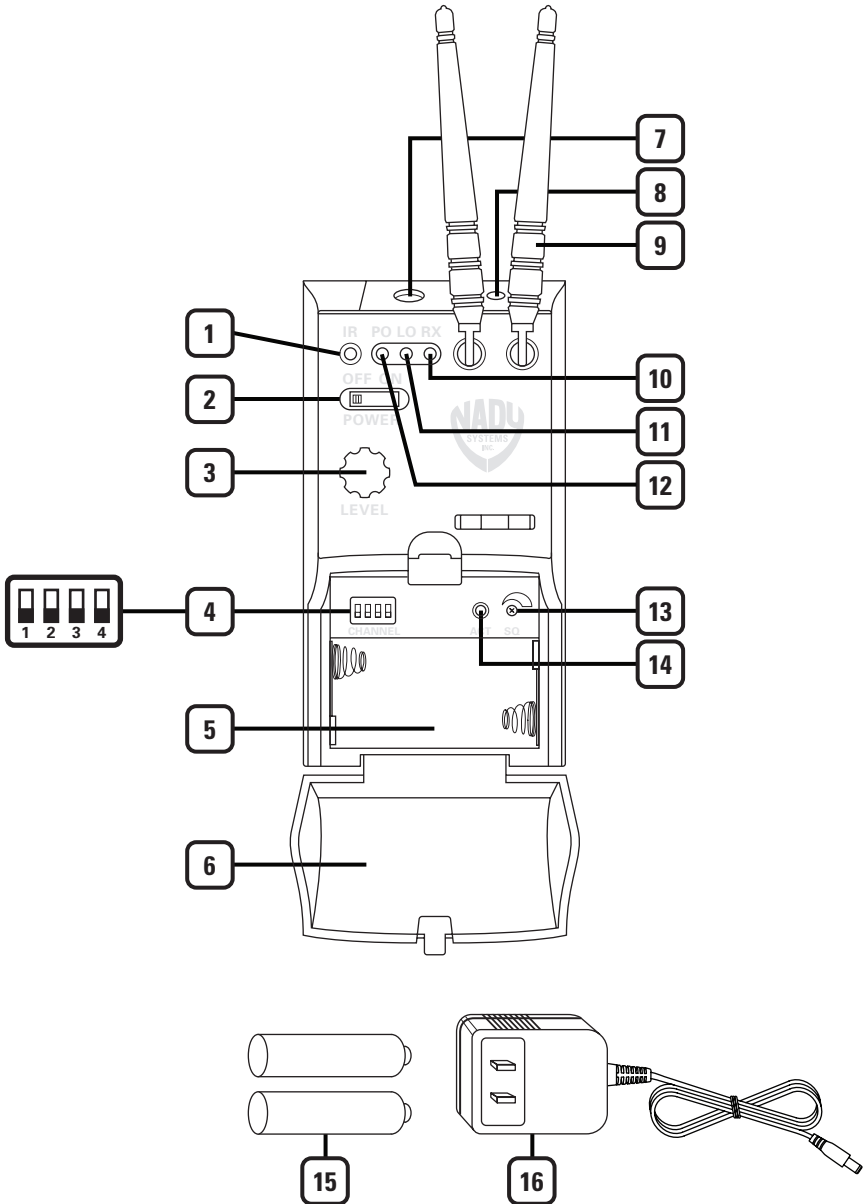

1. ASC™ IR SYNC INFRARED LED WINDOW

For downloading selected Channel (Frequency) to transmitter

2. POWER SWITCH Select OFF/MUTE/ON (MUTE=power On, audio output highly attenuated)

3. VOLUME CONTROL Adjusts the audio output level—at maximum setting the gain will be about +4dB over a direct instrument-to-cord-to-amp connection

4. CHANNEL SELECT DIP-SWITCH Select one of 16 pre-set channels per MGT-16 DIP-Switch Frequency Selection Chart (see page 14)

5. BATTERY COMPARTMENT Insert two AA batteries for optional DC operation, note correct polarity

6. BATTERY COMPARTMENT COVER

7. AUDIO OUTPUT JACK For connecting audio cable

8. DC INPUT JACK For connecting external AC/DC adapter for powering receiver

9. ANTENNAS Dual ¼ wave

10. SIGNAL LED Indicates the received signal from the transmitter

11. LOW BATTERY LED Indicates batteries need replacement (if not using power adapter)

12. POWER ON LED Indicates the receiver is On

13. MUTE (SQUELCH) CONTROL Adjust with a small screwdriver inserted in slot. Controls the mute level for the receiver—turn counter-clockwise for maximum range; turn clockwise, if needed, to minimize noises from outside RF interference upon muting.

Note: Set control carefully. If trim-pot is turned past minimum and maximum adjustment points it may need to be backed up to achieve desired setting.

14. ASC™ IR SYNC BUTTON Press to make the IR link download the receiver's selected frequency to the TX. First, turn on the MT-16A/R transmitter (or turn off and then on again if already on) and position its IR window 6-12" away from the RX IR window, press the SYNC button once and wait one second for the RX to respond. If the IR data download is successful, the receiver SIGNAL LED (10) will light indicating the transmitter is locked in and transmitting.

15. AA BATTERIES Two required for optional battery operation

16. POWER ADAPTER For AC operation (included)

Quick User Controls Guide

MT-16A/R Instrument Transmitter

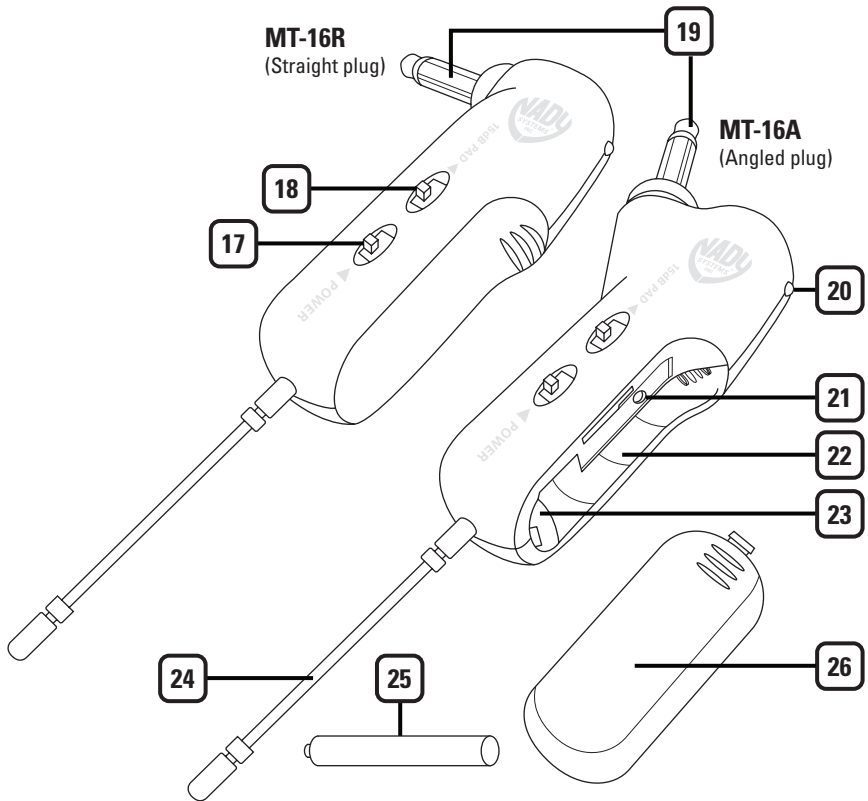

17. POWER SWITCH To power transmitter Off/On

18. 15dB ATTENUATION PAD Select to reduce the input gain by 15dB for higher level audio input signals

19. INPUT ¼" PLUG Connect directly into guitar/bass output jack

20. LOW BATTERY LED Indicates battery needs replacement

21. IR RECEPTOR SENSOR/WINDOW Infrared LED sensor for linking the TX to the RX during IR frequency download

22. BATTERY COMPARTMENT Insert one AAA battery, observing correct polarity

23. INTERNAL AUDIO LEVEL ADJUST Remove battery to access slot and adjust internal trim-pot with small screwdriver for optimal input level setting. **Note:** this is to be done only in rare cases as factory level setting is already optimized for most guitars and basses and 15dB Pad also available.

Note: Set control carefully. If trim-pot is turned past minimum and maximum adjustment points it may need to be backed up to achieve desired setting.

24. ANTENNA Permanently attached antenna

25. BATTERY Single AAA alkaline or NiMH battery required for operation

26. BATTERY COMPARTMENT COVER

IR Sync Selected Frequency Download from MGT-16 Receiver to MT-16A/R Transmitter

(1) **ASC™ IR SYNC INFRARED LED WINDOW**

For downloading selected Channel (Frequency) to transmitter

(21) **IR RECEPTOR SENSOR/WINDOW**

Infrared LED sensor for linking the TX to the RX during IR frequency download.

14. ASC™ IR SYNC BUTTON Press to make the IR link download the receiver's selected frequency to the TX. First, turn on the MT-16A/R transmitter (or turn off and then on again if already on) and position its IR window 6-12" away from the RX IR window, press the SYNC button once and wait one second for the RX to respond. If the IR data download is successful, the receiver SIGNAL LED (10) will light indicating the transmitter is locked in and transmitting.

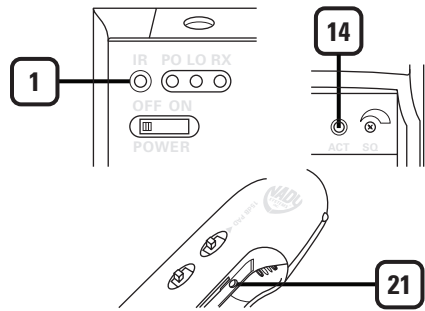

System Operation

MGT-16 Wireless Instrument Receiver

Antennas

The MGT-16 receiver is supplied with **Dual Antennas (9)** attached. They should be extended fully to obtain maximum range. The optimal positions of the antennas are 45 degrees from the receiver and 90 degrees from each other. For maximum range, it is always best to maintain a line-of-sight (no obstructions) between the receiver antennas and the transmitter whenever possible.

Powering the Receiver

The MGT-16 receiver can operate with either two AA size batteries (DC operation) or with the supplied AC adaptor (AC operation).

For DC operation, open the receiver's **Battery Compartment Door (6)** and place two fresh AA batteries in the battery compartment, observing the correct polarity. Two fresh alkaline or NiMH AA batteries will generally provide 6-8 hours performance, but in order to ensure optimal performance

it is recommended that the batteries be replaced after six hours of use, or as indicated by the **Low Battery Indicator (11)**. As the batteries begin to weaken below usable voltage, the low battery indicator will light up continuously, warning that the batteries are now too low and should be replaced as soon as possible. To preserve battery life, keep the receiver Off when it is not in use.

For AC operation, power the receiver with the supplied **AC Power Adaptor (16)**. Plug the adapter's barrel plug into the **DC Input Jack (8)** on the back of the receiver, then plug the adapter into an AC outlet.

AC operation of the MGT-16 receiver is the same as DC operation except that the Low Battery Indicator is inactive when the AC adapter is connected.

Note: When the AC adaptor is used, the installed batteries are automatically disconnected internally and are not operational. The AC adapter only

powers the unit and will not charge NiMH rechargeable batteries if installed. For battery operation the AC adapter must be disconnected.

Note: For quietest optimal performance, use the AC/DC adapter as battery operation raises the noise floor around 4 dB. Generally this is only a concern when playing high-gain lead guitar. For such applications, experiment to see if slightly quieter performance with the AC/DC supply is preferred.

Turn on the MGT-16 receiver by sliding the **Power Switch (2)** to the second position (receiver On but audio output Muted/Attenuated), or to the third position for normal operation (receiver On and audio un-Muted). **The Power LED (12)** will light up and the receiver is operational.

Adjusting the Squelch

The **RF Squelch (13)** control should be adjusted counterclockwise to the minimum RF squelch setting at which the **RF Signal LED (10)** remains on while your transmitter is in normal use, up to the maximum operating range anticipated in use for your application. However, in areas of high RF activity, the squelch control may need to be adjusted clockwise. If the transmitter is off and the receiver RF Signal LED indicator is flickering or stays on continuously, the squelch should be adjusted to a higher level (clockwise for less mute sensitivity level) to stop the flickering. Be careful not to select too high a clockwise setting as this may reduce the operating range to below what is needed. A range walk test will help in selecting the proper level. If the range is not critical, note that a clockwise (maximum squelch) setting will also yield a quieter mute function, which may be desirable in certain applications. The squelch level is factory preset at maximum sensitivity and operating range (i.e. counterclockwise for minimum squelch/maximum usable range).

Note: Set controls carefully. If trim-pots are turned past minimum or maximum adjustment points they may need to be backed up to achieve desired setting.

Selecting the MGT-16 Receiver Channel and IR Sync

The **Frequency Select DIP Switches (4)** are used for selecting one of 16 preset frequencies. Simply position the DIP switches to a desired open channel on the receiver. There should be no flickering of the **RF Signal LED (10)** with the transmitter off. See the *MGT-16 DIP-Switch Frequency Selection Chart* on page 14 for the correct switch position for each of the 16 available channels. Once you have selected the receiver frequency it can easily be downloaded to the transmitter to establish the necessary RF connection. For help in finding open channels, see *RF Interference and Finding Open Channels* on page 12.

The **IR Sync Button (14)** on the MGT-16 receiver is used to transfer the selected frequency info from the receiver to the transmitter for quick synchronization prior to use. Begin programming by holding the wireless transmitter's **IR Receptor/Sensor Window (21)** about 6-12" from the receiver's **IR Synchronizing Infrared LED Window (1)**. Press the IR Sync Button once to begin the IR sync download of the selected frequency to the transmitter.

Note: To insure proper synchronization, the transmitter must always be just turned on, or else turned off then on again before syncing.

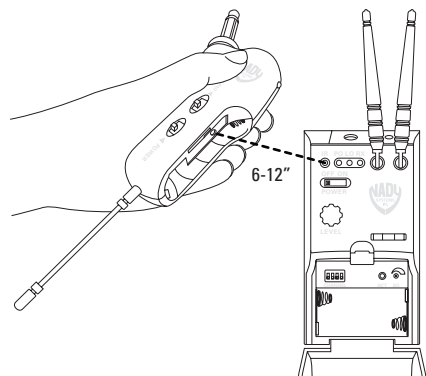

MT-16A/R Instrument Transmitter

When the **RF Signal LED (10)** on the receiver lights up, the system frequency is properly synchronized. To change to a different frequency, reset the **Frequency Select DIP Switches (4)** and sync the transmitter again to the new selected frequency first, after turning the transmitter off and then on again. If no action is taken during the 10 seconds of active data transfer (i.e., the transmitter is not turned on or properly positioned) the receiver and the transmitter units do not link and transmitter's previously programmed channel remains unchanged.

Note: *Only one transmitter can be used with one receiver. It is not possible to use two transmitters on the same frequency and mix the output of these transmitters into one wireless receiver.*

Note: *The IR link is infrared light and works best when this data transfer is accomplished in a light-shielded or darker environment. It may not be successful in a brightly lit area. If the transfer fails, repeat the procedure in a darker location or somehow shield the link from outside light to successfully program the transmitter with the selected channel info from the receiver.*

Connecting Audio Output

The MGT-16 receiver's **Audio Output Jack (7)** is a ¼" unbalanced line out and its level is controlled by the **Volume Knob (3)**. Plug an audio cable with a ¼" mono (tip/sleeve) plug into the audio output jack and plug the other end into your pedal board or amplifier as you would with a direct cord from the instrument. When the Volume knob is set to maximum receiver volume setting, the system audio output is approximately +4dB higher than a direct instrument-to-cord-to-amp connection.

Note: *As when making any connection, make sure the amplifier volume control is set at the minimum level before plugging in the receiver to avoid possible speaker damage.*

Your MGT-16 receiver is now operational and ready to use. Once you have completed the above steps, proceed to the following instructions for the MT-16A/R Instrument transmitter.

Powering the Transmitter

The MT-16A/R Instrument transmitter requires one **AAA size battery (25)**. To install the battery, push the locking tabs on the **Battery Cover (25)** and push out to expose the **Battery Compartment (22)**. Insert one fresh AAA battery according to the correct polarity as indicated on the transmitter body. Close the battery cover, ensuring the cover is snapped shut. A fresh AAA alkaline battery generally provides up to 6-8 hours of operation, but in order to ensure optimal performance it is recommended that the battery be replaced after six hours of use or as indicated by the **Low Battery Indicator (20)**.

To turn on the transmitter, slide the **Power Switch (17)** in the direction of the arrow. The Low Battery Indicator will flash once. The unit is now on and the receiver's **RF Signal LED (10)** will light up if the transmitter has been frequency synchronized to the receiver's selected frequency as per below.

As the batteries weaken, the Low Battery Indicator will flash to warn that the battery level is too low and should be replaced as soon as possible. To preserve battery life, turn the transmitter Off when not in use. To turn the transmitter Off, slide the Power Switch in the opposite direction of the arrow.

The transmitter has a **15dB Pad (18)** On/Off switch which can be selected to attenuate high output instrument pick-up levels if needed to reduce distortion through the system. To turn On, slide the switch in the direction of the arrow. Turning opposite the arrow indication is for standard 1:1 gain operation and is recommended for normal, optimal low-noise operation.

The transmitter has an **Internal Audio Level Adjust (23)** to set the audio deviation level. It is accessed by inserting a small screwdriver into the slot. Turning this

trim-pot counterclockwise reduces overall system audio output (thus lowering distortion but raising background noise), while turning clockwise increases overall system audio output (thus lowering background noise but raising distortion). The Audio Level Adjust is factory set to the mid position, which is the optimal setting for normal operation.

Note: The Audio Level Adjust is not intended for high-input signal adjustment—the 15dB pad is provided for that purpose. It is for use only in extreme cases during which satisfactory audio cannot be achieved with the pad alone.

Note: Set control carefully. If trim-pot is turned past minimum or maximum adjustment points, it may need to be backed up to achieve desired setting.

Programming the MT-16A/R to the Selected Channel

Before beginning operation, the MT-16A/R transmitter must be synchronized with the selected frequency from the receiver using the **IR Receptor/Sensor Window (21)** on the transmitter and the **IR Sync Window (1)** on the receiver (see *Selecting the MGT-16 Receiver Channel and IR Sync* on page 8).

After first turning the transmitter on (or off and then on again if already on), begin programming by holding the transmitter's IR Receptor/Sensor Window about 6-12" from the receiver's IR Synch Window. Press the **IR Sync Button (14)** once to begin the IR sync download of the selected frequency to the transmitter. Upon successful data transfer (usually in less than two seconds) the transmitter will transmit a radio signal on the same channel (frequency) as the receiver. The **Signal LED (10)** on the receiver will light up, indicating that the link is completed. If all the necessary steps noted above are not taken during the ten seconds of active data transfer, the receiver and the transmitter units will not link and the transmitter's previously programmed channel remains unchanged.

When programming is finished, close the battery compartment door, ensuring that it latches. The MT-16A/R is now ready for use.

Note: Manually matching the transmitter frequency without the receiver is not possible. For proper operation, the transmitter must have the same channel as selected on the receiver.

Operating the MT-16A/R Instrument Transmitter

During normal operation with the unit powered On, the MT-16A/R transmitter should be fully inserted onto the instrument (guitar, bass, etc.). When ready to play, slide the **Power Switch (2)** to On position in the direction of the arrow. The receiver **Signal LED (10)** should light up if system is properly synchronized. Adjust the volume on the receiver (see *Connecting Audio Output* on page 9) for unity gain (one-to-one) with a hard-wired cord. Or, select up to an added 4-5dB boost by adjusting the receiver volume to maximum for normal use with guitars and bass guitars. A listening test prior to use will determine which receiver volume and transmitter input pad settings are best for your application. To Mute/un-Mute (attenuate) the audio during use, set the receiver power switch to the second (Mute) position. Or, just turn off the transmitter with the **Transmitter Power Switch (17)**. The Signal LED will turn off and the audio will be muted (Off). When ready to play again, slide the receiver's power switch to the third (On) position. Or, just turn on the transmitter.

Note: While playing, the audio level should be adjusted on the instrument as when using a hard-wired cord.

Specifications

MGT-16 SYSTEM

Frequency Response	50Hz–16kHz (-3dB)
Dynamic Range	120dB
Oscillating System	Phase Lock Loop (PLL)
Total Harmonic Distortion (THD)	<0.8%
RF Carrier Frequency Range	902.40MHz–923.70MHz
Modulation	FM (F3E), +/-30KHz normal
Operating Range	Up to 250 feet (typical, depending on site conditions)

MGT-16 RECEIVER

Controls	Audio Level, Power ON/MUTE/OFF, Frequency Select DIP-switches, IR sync button
Connectors	Unbalanced ¼", DC Adapter input jack
LED Indicators	Power ON (Red-continuous), Low Power (Orange-continuous), RX reception (Green)
Antennas	Dual ¼ wave, adjustable orientation
Signal-to-Noise Ratio	>105dB (w/AC/DC power supply)
Receiver Sensitivity	-110dBm nominal, 12dB SINAD
Squelch Sensitivity	-95dBm (minimum/normal setting), adjustable
Output Impedance	1.0KΩ
Power Consumption	DC: 3V/ 115mA or AC/DC adapter: 10VDC/200mA
Battery	Two AA alkaline or NiMH
Battery Life	Up to 8 hours
Dimensions	2.75" W x 5.00" D x 1.88" H (7.0 cm x 12.7 cm x 4.78 cm)
Weight (w/o batteries)	5.7 oz (161.6 g)
Housing Construction	ABS Plastic

MT-16A/R TRANSMITTER

RF Power Out	25mW nominal, 50mW maximum
Harmonic & Spurious Emissions	-50dB
Controls	Power ON/OFF, 15dB Attenuation Pad select switch
LED Indicators	Power ON (Red-single flash), Low Battery (Red flash)
Input Impedance	500KΩ
Power Consumption	DC 1.5V/90mA
Battery	One AAA alkaline
Battery Life	Up to 8 hours
Antenna	¼ wave, permanently attached
Dimensions	MT-16A: 4.5" W x 2.0" D x 1.0" H (11.43 cm x 5.08 cm x 2.54 cm) MT-16R: 3.5" W x 2.5" D x 1.0" H (8.9 cm x 6.35 cm x 2.54 cm)
Weight (w/o batteries)	MT-16A: 1.2 oz (34 g) MT-16R: 1.1 oz (31.2 g)
Housing Construction	ABS Plastic

Specifications subject to change at any time without prior notice for purposes of product improvement

Cautions and Troubleshooting

No or Low Audio

If you are not getting audio through the system, carefully re-check all setups. Especially note that the receiver and transmitter must be set to operate on the same RF channel. Make sure that the receiver **Power Switch (2)** on the MGT-16 receiver is not in the second position (audio muted/attenuated). The receiver's **Unbalanced Audio Out (7)** is adjustable, so make sure the **Volume Control (3)** is set properly.

RF Interference and Finding Open Channels

If you encounter slight receiving interference when the transmitter is far from the receiver, it can often be overcome by adjusting the receiver's **Squelch Adjust (13)** (see *Adjusting the Squelch* on page 8). If you receive interference on a selected channel with the transmitter Off, you must reprogram the receiver and transmitter to a different channel.

To reprogram, you must first find an open channel. To do this, follow the operating procedure outlined in *Selecting the MGT-16 Receiver Channel and IR Sync* on page 8. With the transmitter Off, change the receiver DIP switches setting to one of the 16 channels until you find one for which the **Signal LED (10)** doesn't flicker or light up. Also, for optimal interference-free operation, the Signal LED must not flicker or light up on any of the three immediately adjacent channels, both above and below the selected channel (i.e., a field of seven adjacent channels, with the chosen channel in the middle, should all be clear). If operating multiple MGT-16 systems simultaneously, repeat this procedure every time a new channel is selected, with all other transmitters and receivers turned on.

It is important to note that wireless frequencies are shared with other radio services. According to current FCC regulations, wireless microphone operation is not protected from interference from other licensed operations in the band. If any interference is received by a government or non-government operation and wireless microphone use is deemed responsible for the interference, the wireless microphone must cease operation or change frequencies. **Note:** *This requirement is applicable in the U.S. only.*

















Note: *If the Signal LED is lit, this indicates good signal strength in operation. If the Signal LED remains lit with the transmitter Off, this indicates the presence of likely RF interfering signals at that location. Should this occur, select a different channel.*

Miscellaneous Tips

- The receiver antennas should be kept away from any metal surfaces whenever possible as they can reflect away or shield the incoming RF signal.
 - When inserting batteries, make sure they are inserted with the correct polarity.
 - Before operation, confirm that the receiver and associated transmitter are tuned to the same frequency/channel.
 - After making a receiver channel change, make sure that the corresponding change is also made on the matching transmitter.
 - Use only fresh alkaline or fully charged NiMH batteries. Do not use “general purpose” carbon batteries. When batteries are weak, replace all of them at the same time. Do not mix new and old batteries, or different types of batteries.
 - Position the receiver so it has the least possible obstructions between it and the transmitter. Line-of-sight is best.
 - During operation, the transmitter and receiver should be as close as possible to each other for optimal results.
 - Although placement of the receiver on the floor provides good performance in most applications, for best operation the receiver should be placed at least 3 feet (1 meter) above the ground and 3 feet (1 meter) away from a wall or metal surfaces. The transmitter should also be at least 3 feet (1 meter) from the receiver.
- Keep antennas away from noise sources such as motors, automobiles, neon light, signal processors, computers, and large metal objects.
- A receiver cannot receive signals from two or more transmitters simultaneously.
 - Turn the transmitter off when it is not in use. For longest life, remove the batteries if the unit is not going to be used for a long period of time as the transmitters draw a tiny residual current even when off in order to maintain the programmed settings. Also, since batteries installed for a long time can sometimes corrode and/or leak, causing damage, it is generally recommended that batteries be removed whenever the transmitters are not being used.
 - When using the MT-16A/R with guitars and basses: Scratchy noises can sometime occur when electric guitars with dirty pots or connections are used with a wireless system. If you hear scratchy noises, we suggest these steps to eliminate them:
 - 1) Make sure all guitar volume and tone pots are clean and all contacts are solid. This is very important.
 - 2) Consider soldering a 47pF capacitor across the pot to ground terminal of the guitar’s volume and tone pots—this will provide extra filtering.

MGT-16 DIP-Switch Frequency Selection Chart

Frequency Plan: 902.4MHz-923.7MHz (16 Channels) U.S.

Channel	Selection	Frequency	Channel	Selection	Frequency
1		902.4	9		913.9
2		904.8	10		914.0
3		905.4	11		916.0
4		906.7	12		917.9
5		907.8	13		919.7
6		909.8	14		920.0
7		910.8	15		921.1
8		911.2	16		923.7

Accessories

Part Number	Description
AC-MGT-16	10VDC/200mA AC/DC receiver power supply adapter included

Service Information

In the U.S. If you are experiencing operational problems with your system, please refer to the Support page at www.nady.com for assistance. Should your wireless system require service, please contact the Nady Service Department at (510) 652-2411 to obtain a Return Authorization (R/A) Number and service quote (if out of warranty). Make sure the R/A Number is clearly marked on the outside of the package that you are returning.

If your unit is out of warranty, please enclose a cashier's check or money order (or pay by credit card) per instructions by the Nady Service Department. Ship your unit prepaid to: Nady Systems, Service Department, 6701 Shellmound Street, Emeryville, CA 94608. Include a brief description of the problem you are experiencing. For service of a unit under warranty, please follow the instructions in the following section.

Outside the U.S. For service or warranty matters please contact the Nady distributor in your country through the dealer/store from which you purchased this product.

Do not attempt to service this unit yourself as it can be dangerous and will also void the warranty.

One-Year Limited Warranty

Nady Systems, Inc. warrants to the original consumer purchaser that the unit is free from any defects in material or workmanship for a period of one year from the date of original retail purchase. If any such defect is discovered within the warranty period, Nady Systems, Inc. will repair or replace the unit free of charge, subject to verification of the defect or malfunction upon return to Nady Systems. Please do not return your Nady product to the store where it was purchased as Nady Systems handles your warranty service directly. Communication with our Service Department is the most efficient means of servicing your unit and we are dedicated to keeping you a satisfied customer.

To the extent permitted by law, any applicable implied warranties, including warranties of merchantability and fitness are hereby limited to one year from the date of purchase. Consequential or incidental damages resulting from a breach of any applicable express or implied warranties are hereby excluded. This warranty is in lieu of all other agreements and warranties, general or special, express or implied and no representative or person including a Nady dealer, agent, or employee is authorized to assume for us any other liability in connection with the sale or use of this Nady Systems' product.

Whereas some states do not allow limitations on how long implied warranties last, and do not allow exclusion of incidental or consequential damages, the above limitations and exclusions may not apply to you. This warranty gives you specific legal rights and you may also have other rights which may vary from state to state.

This warranty is subject to the following conditions:

- 1) This system must have been purchased from an authorized Nady dealer and all warranty service must be performed by Nady's service department. Any service not performed by Nady will automatically void this warranty.
- 2) Items not covered: physical damage resulting from improper handling of the unit in transit from the factory by the shipper (Nady Systems is not responsible for such damage and all such claims must be made against the shipping company by the consignee); defects caused by normal wear of the product (expendable parts are typically connectors, cables, potentiometers, switches and similar components); damage or defects caused by abuse, neglect, accident, failure to connect or operate the unit in any way that does not comply with applicable technical or safety regulations, or improper repair, excessive heat or humidity, alteration or unreasonable use of the unit, causing cracks, broken cases/housings or parts; damage caused by leaking batteries; finish or appearance items; items damaged in shipment en route to Nady Systems, Inc. for repair. The warranty is null and void if any Nady serial number has been removed or defaced.

How To Obtain Service:

- 1) If factory service is required, please contact our Service Department at (510) 652-2411 for a return authorization (R/A) number. Make sure the R/A number is clearly marked on the outside of your package. (Please note: if an R/A number is not included, our Shipping Department cannot accept your package.)
- 2) Send the unit back to Nady Systems, 6701 Shellmound Street, Emeryville, CA, 94608, freight pre-paid. You must include proof of date and place of purchase (i.e., photocopy of your bill of sale) or Nady cannot be responsible for repair or replacement. Nady Systems, Inc. will not repair, nor be held responsible, for any units returned without proper identification, return address, and R/A number clearly marked on the package.
- 3) Per the above, Nady will perform all warranty service and return the unit to you at no charge. Nady Systems will inform the buyer if product sent in does not meet the terms of this warranty and will provide a quote for fixing the unit and/or shipping it back exclusively at the buyer's expense.



6701 Shellmound Street | Emeryville, CA USA 94608
T 510.652.2411 | F 510.652.5075 | www.nady.com