

PEM-500

Wireless Personal In-Ear Monitor
16 Channel UHF PLL Synthesized



OWNER'S MANUAL



CONTENTS

CONTENTS	2
INTRODUCTION	3
WARNING	4
SYSTEM FEATURES	5
OPERATION	6
PEM-500T TRANSMITTER	6
PEM-500R RECEIVER	10
SPECIFICATIONS	14
SERVICE	15

INTRODUCTION

Thank you for purchasing a Nady PEM-500 Wireless Personal In-Ear Monitor System and congratulations on your choice. This system offers all of the advantages of wireless in-ear monitoring—mobility, more focused audio, freedom from feedback, and elimination of transport issues associated with conventional floor monitors—as well as the longterm health benefits of safe listening levels. For the first time, a wireless in-ear monitor system combines state-of-the-art advanced frequency-agile PLL synthesized UHF technology, high-end performance, ease of use, and unprecedented affordability. The PEM-500 offers a choice of 16 user selectable UHF channels in both the transmitter and receiver(s), as well as stereo (MPX system) or mono mode transmission. This system is indispensable for live-stage music performance, and is loaded with features previously found only in units costing several times more.

USING THIS MANUAL

This booklet gives instructions for the operation of the PEM-500 Wireless In-Ear Monitor System. Please read the instructions for your system completely before operating unit. This manual first lists the features of the PEM-500, and then takes you step-by-step in explaining how to operate your new system, both transmitter and receiver. Each section gives you detailed operating instructions. Also included in this manual are system specifications and servicing information.

WARNING

USING THIS SYSTEM AT EXCESSIVE VOLUMES CAN CAUSE PERMANENT HEARING DAMAGE. ALWAYS USE AS LOW A VOLUME AS POSSIBLE.

The Occupational Safety Health Administration (OSHA) has established the following guidelines for maximum time exposure to sound pressure levels (SPL) before hearing damage occurs:

90 dB SPL @ 8 hours
95 dB SPL @ 4 hours
100 dB SPL @ 2 hours
105 dB SPL @ 1 hour
110 dB SPL @ 1/2 hour
115 dB SPL @ 15 minutes
Avoid exposure to 120 dB or greater
SPL or irreversible ear damage may result.

(Note: It is difficult to measure the SPL present at the eardrum in live sound applications. The volume present will be affected by the level setting of your PEM-500R, the ambient stage sound from your other instruments and speakers, and the quality of and fit of your in-ear speakers.)

Always avoid prolonged listening at excessive sound pressure levels. Use the following guidelines to use this system safely:

1. Turn up the volume to your earphones only enough to hear properly. The PEM-500 can provide a high quality monitor mix at significantly lower decibel levels than floor monitors. Whenever possible, use the system with the limiter in the PEM-500R receiver ON.
2. Just as with any in-ear monitor system, The PEM-500 works best when used exclusively by all performers on stage (without any wedges or side monitors). The high sound pressure levels produced by floor monitors (especially if the band plays loud) can bleed through the in-ear monitor earbuds and, in the worst cases, hinder their effectiveness. Experiment with your overall mix to get the maximum benefit from your PEM-500.
3. Turn down the volume immediately if you experience any pain or hearing discomfort or ringing in the ears after use.
4. Have an audiologist check your hearing and ears regularly. If you experience any wax buildup in your ears, do not use the system until an audiologist examines your ears.
5. Wipe the earphones with an antiseptic before and after use to avoid infection. Stop using the earphones if they cause discomfort or infection.



An equilateral triangle enclosing an exclamation point is intended to alert the user to the presence of important operating and service instructions in the literature enclosed with this unit.

SYSTEM FEATURES

- Available on selected frequency bands within the UHF band for interference-free, long-range performance (up to 8 systems can be operated simultaneously, depending on country and frequency band)
- System consists of PEM-500T transmitter and one bodypack PEM-500R receiver, both of which offer 16 channel user selectability. Any number of additional receivers can also be operated with the same transmitter if they are all set to the same channel.
- Proprietary companding circuitry for wide Dynamic Range and clear, natural sound
- Operating Range: Up to 300 feet typical (depending on site conditions)
- Rugged, foam-padded traveling case provides easy, safe transport and storage

PEM-500T Transmitter

- Rugged, all metal half-rack that can be rackmounted singly or side-by-side with optional rack kits
- Microphone input allows wireless cueing of performers on stage
- Front panel features input level control, stereo headphone monitor output jack and volume control, select button for choosing one of 16 UHF channels, LED channel display, and Left/Right 10-segment audio input level displays.
- Back panel provides BNC jack for the detachable antenna, a Stereo/Mono select switch, a 1/4" TRS balanced microphone input, and XLR jacks for Left and Right Line inputs.
- Externally powered by AC power adapter

PEM-500R Receiver

- Portable bodypack receiver features a power switch, switchable built-in volume limiter, output level control, stereo/mono select switch, and two-color (red/green) 3-way unit ON/Signal/Low Battery LED indicator.
- Operates up to 6 hours (depending on volume) on a 9V alkaline battery
- Each receiver is supplied with a pair of miniature, lightweight (yet powerful) in-ear speakers with soft rubber mounts in 3 sizes (small, medium, and large) designed for "custom" form-fitted comfort and optimum acoustic transfer and isolation.
- Rear clip can be rotated 90° for attaching receiver either vertically or horizontally to clothes.

PEM-500T TRANSMITTER

1. Rackmounting the transmitter

The PEM-500T requires no installation and can be used on any flat surface. However, in some applications rack mounting is preferred. There are 2 options available for rackmounting the PEM-500T transmitter: singly or side-by-side with another PEM-500T transmitter.

- Single mounting: The PEM-500T is supplied with RE-5 **RACK EARS (1)** which can be attached with the screws provided on the front of the side panels to enable rackmounting the receiver.
- Side-by-side dual mounting: Two PEM-500T transmitters can be rackmounted side-by-side using the optional RKT-25 **RACK KIT TRAY (2)** which holds 2 transmitters.

(Note: Do not mount the transmitter(s) in a rack directly above an amplifier or other source of high heat—this could degrade the performance of the PEM-500T. Always ensure adequate airflow and heat dissipation in any rack configuration.)

2. Powering the Transmitter

Plug the **14V AC ADAPTER (3)** provided into the **AC INPUT JACK (4)** on the back of the receiver. Then plug the power supply into an AC outlet.

Press the **POWER SWITCH (5)** once to turn on the transmitter. The **POWER ON LED (6)** will now light and the transmitter is operational.

3. Antenna

Connect the **ANTENNA (7)** or optional remote antenna on the back panel to the **ANTENNA JACK (8)**. Optimal antenna position is vertical. For maximum range, it is always best to maintain a line of sight (no obstructions) between the transmitter antenna and the receiver(s) at all times whenever possible.

4. Connecting the Audio Input

The PEM-500T transmitter features a 1/4" TRS balanced **MIC INPUT (9)** and a line level balanced XLR jack for the **LEFT** and **RIGHT LINE INPUTS (10)**. The MIC INPUT allows the use of a microphone alone for easy cueing of performers while on stage, which can be useful in many applications. It can be used even with input signals also connected to the **LINE INPUTS**. Select the input jack appropriate for the signal(s) you are feeding to the transmitter:

- For a microphone input, plug a balanced 1/4" TRS or an unbalanced 1/4" TS cable from a dynamic microphone into the **MIC INPUT**.
- Stereo monitor mixes from your console can be connected to the **LEFT** and **RIGHT LINE INPUTS** with balanced XLR connectors. Mono monitor mixes can also be input in this manner. Select STEREO for stereo inputs and MONO for mono inputs, as appropriate, with the **STEREO/MONO SWITCH (11)**. Mono signals are transmitted on both the left and right channels equally with the volume adjustable by the **AUDIO LEVEL CONTROL (12)**. The gain of stereo signals can be further adjusted separately (L/R) by the console monitor feed. With the **STEREO/MONO SWITCH** set to MONO, a stereo input signal will be transmitted as mono. If the switch is set to STEREO, a mono signal will still be transmitted as mono. If a signal is input only to one of either the left or right **LINE INPUTS** and the switch is set to STEREO, it will only be transmitted on that side. However, if the switch is then set to MONO, it will be transmitted on both sides as a MONO signal. See also **Selecting Stereo or Mono Operation** in the PEM-500R Receiver section.

*(Note: As when making any connection, make sure that the PEM-500T **AUDIO LEVEL CONTROL** and the console output levels are set at minimum volume before plugging into the transmitter. This will avoid possible loud transients in the PEM-500R receiver if it is already turned on, and with earphones plugged into the user's ears.)*

5. Selecting a Channel/ Multiple System Operation

Both the PEM-500T transmitter and PEM-500R receiver offer a choice of 16 channels in the UHF band. Select an open frequency that doesn't interfere with any other PEM-500 or UHF wireless mic system you are also using by pushing the **CHANNEL SELECT BUTTON (13)** on the front panel of the PEM-500T until the channel you want is displayed on the **CHANNEL LED DISPLAY (14)**. You will also need to select the same channel for the transmitter (see Transmitter Operation instructions above). If different mixes are required for the different performers, additional PEM-500T transmitters and receivers set to other channels must also be used, and each transmitter must be fed a different mix from the console as desired. Depending on the band(s) you are using and open channel availability within the band(s), up to 8 PEM-500 systems on different frequencies can be operated simultaneously to provide multiple discrete mixes to the performers.

[Note: Never set more than ONE transmitter to the same operating frequency]

[Note: After selecting a frequency on the transmitter, you must also check with the receiver to ensure that the chosen channel is open (i.e., no other transmissions from other sources, such as UHF TV channels in your area, operating at the same frequency). Turn off the PEM-500T transmitter, and monitor the signal from the PEM-500R (see PEM-500R instructions, pg. 10). It should be silent. For optimum operation and range, if you receive any transmissions or static you must choose another channel that is clear.]

[Note: If, after you complete the set-up, you experience interference or unsatisfactory audio performance, change the channel until the problem goes away. In the extremely rare circumstance that such a problem persists, turn off all UHF wireless mics being used or move their receivers physically away from the PEM-500T transmitter. In some instances, UHF wireless mics and the PEM-500 system can interact if they are too close in frequency. Contact the NADY SYSTEMS Service Department for further information if necessary (see SERVICE, pg.15)]

6. Adjusting Levels

Adjust the selected audio input level for optimum level for transmission with the **LEVEL CONTROL (12)**. Adjust the control so that the top LEDs on the 10-segment Left and Right **LED LEVEL DISPLAYS (15)** light intermittently only on loud peaks. This control adjusts both the left and right signals simultaneously in the same manner. For added control and separate levels on stereo inputs, use the left and right stereo monitor output level control on your console providing the signal.

7. Headphone Monitoring

The sound technician can monitor the signal being transmitted with a wired pair of headphones via the stereo 1/4" **TRS MONITOR OUTPUT JACK (16)**. The volume can be adjusted as desired with the **HEADPHONES VOLUME CONTROL (17)**. Both the left and right channels of a stereo signal are adjusted simultaneously by this control in the same manner.

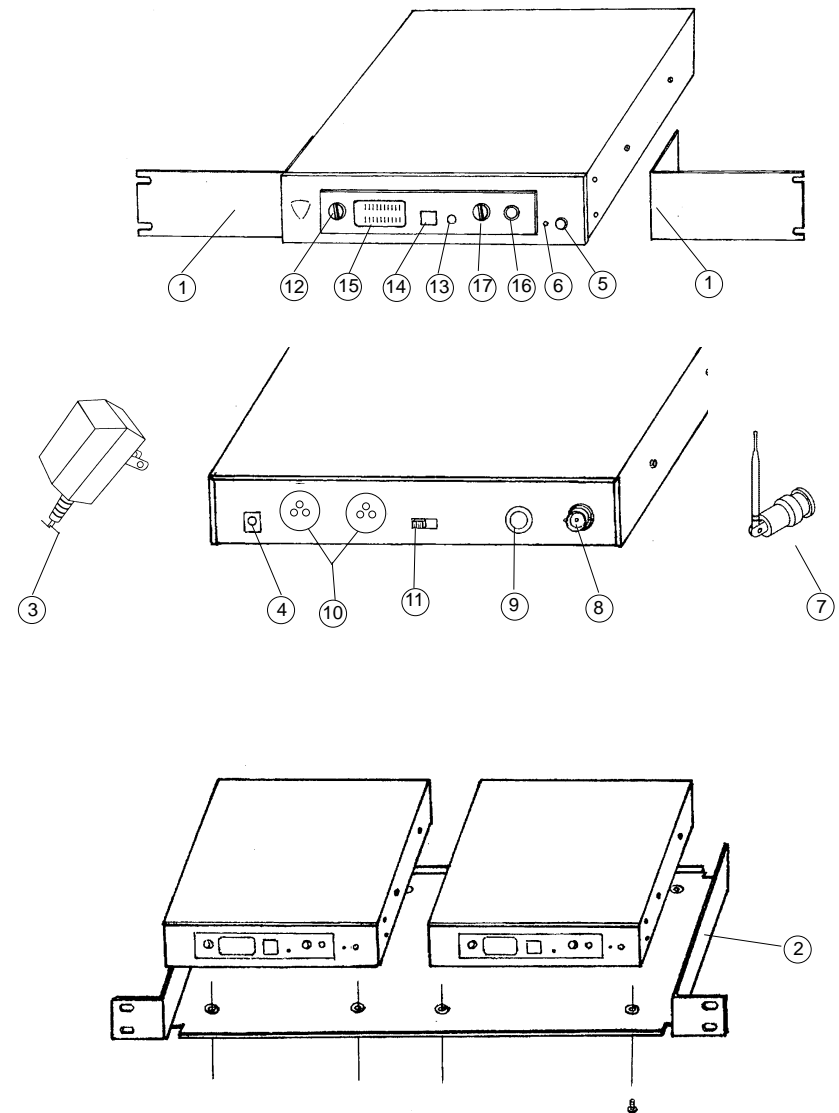

PEM-500R RECEIVER

1. Multiple Monitor Mixes

Any number of PEM-500R receivers can be used with a single PEM-500T transmitter set to the same channel. Although there are individual controls on each receiver allowing different levels of volume, each receiver will receive the same transmitted monitor mix (see **Selecting Stereo or Mono Mode Reception** below for exceptions). If different mixes are required for the different performers, additional PEM-500T transmitters and receivers set to other channels must also be used, and each transmitter must be fed a different mix from the console as desired.

(Note: Never set more than ONE transmitter to the same operating frequency.)

2. Powering the Receiver(s)

Slide down and flip open the **BATTERY COMPARTMENT (18)** and insert a fresh **9V BATTERY (19)**, observing the correct polarity. Turn on the receiver with the **POWER SWITCH (20)**. If the battery has usable strength, the 2 color **UNIT ON/SIGNAL/LOW BATTERY LED (21)** will glow red if the transmitter is OFF and green if it is on and tuned to the same channel as the receiver. The battery should last up to 6 hours, depending on the music content and volume, but it is recommended that it be changed every 3-4 hours if possible. If the battery is too weak for operation, the LED will not light at all or flash alternate green/red if the transmitter is turned on, and on the same channel, or flash red if the transmitter is turned off. If this occurs during use, immediately change the battery to ensure optimum continuing performance.

3. Selecting the Channel

Inside the open **BATTERY COMPARTMENT**, use a small screwdriver and adjust the **CHANNEL SELECTOR CONTROL (22)** to the same channel as selected above for the transmitter with which you will use this receiver. The **UNIT ON/SIGNAL/LOW BATTERY LED** will change from red to green when the same channel is selected, indicating reception of the signal from the associated PEM-500T transmitter.

4. Selecting Stereo or Mono Mode Reception

Switch the **STEREO/MONO CONTROL (23)** in the **BATTERY COMPARTMENT** to stereo or mono reception to match the transmission mode already selected for the transmitter, as per the **Connecting the Audio Input** section of the PEM-500T transmitter instructions above. You can also try different combinations for different applications. For example, if multiple PEM-500R receivers are being used with one PEM-500T transmitting in stereo, the different performers may select either a stereo mix with the **STEREO/MONO CONTROL** (which may feature vocals on one side and the rest of the mix on the other), or a mono mix (with the vocals and music mixed together). Such capability adds to the versatility of the system by allowing more personal control of the individual sound received by different performers all listening to the same transmitted mix.

5. Connecting the In-Ear Monitor Speakers

The PEM-500R is provided with a **3.5 mm TRS STEREO EARPHONE MINI JACK (24)** for connecting the **EARBUD SPEAKERS (25)** supplied. These miniature in-ear speakers can be inserted in the ear with the foam screens supplied as standard portable sound system earphones. For better isolation from ambient stage sounds and a more secure fit, 3 sets of soft "form-fit" **RUBBER IN-EAR MOUNTS (26)** are provided to fit all sizes (small, medium and large). Select the size that best fits in your ears most comfortably. Remove the foam screen from the earphones and slip the **RUBBER MOUNTS** over each speaker. Insert the **MOUNTS** (with speakers), one in each ear.

(Note: Wipe the earphones and rubber mounts with an antiseptic before and after each use to avoid infection. Stop using the earphones if they are causing discomfort or infection.)

[Note: For best results and sound, a pair of custom-fitted ear transducers, supplied with soft rubber mounts cast by an audiologist from your own ear cavity, are recommended. Although expensive, these earphones will provide the most natural, full frequency response, best acoustic isolation and longest-term wearing comfort. Such units can be ordered from suppliers such as Sensaphonics (www.sensaphonics.com) and Ultimate Ears (www.ultimateears.com). Contact one of these suppliers directly for more information on their custom earphones.]

6. Attaching the Receiver

The PEM-500R can be slipped into a pocket or clipped onto clothes or a belt with the **BELT CLIP (27)**. Note that for utmost versatility and convenience, this clip can be rotated 90° for attaching receiver either vertically or horizontally on clothes or belt as desired. To rotate clip, loosen the Phillips screw holding the clip, change the position as needed, and retighten the screw to secure the clip.

7. Adjusting Ear Monitor Volume

After the PEM-500T transmitter has been adjusted to optimum volume and Stereo or Mono reception is selected simultaneously on both the transmitter and receiver as per the preceding instructions, the received volume can be adjusted as desired. Select the volume with the thumbwheel **VOLUME CONTROL (28)**. As per the preceding WARNING section, turn up the **VOLUME CONTROL** only far enough to hear properly. For longterm ear safety, it is highly recommended that you always select the volume limiting provided by the **LIMITER ON/OFF SWITCH (29)** in the **BATTERY COMPARTMENT**.

(Note: Ringing in the ears after use indicates the gain levels you have selected may be too high. Either select LIMITER ON or turn down the VOLUME CONTROL. You may also need to lower the overall volume of the band instruments and amplifiers to enable more comfortable and safer listening levels. See the WARNING section, pg.4)

8. Testing Receiver Range

Wearing your receiver and earphones, walk around the stage area and listen for audio quality. Depending on room size, obstructions, amount of reflective metal surfaces, and other conditions that may affect RF transmission, it is normal that the audio may disappear or "drop out" in certain locations. Such zones, otherwise known as "null spots" are very small and fixed in location if you are within 100 feet of the transmitter, and will become larger as you approach the ultimate range of your system in that location (up to 300 or so feet, depending on site conditions). Generally, it is possible to eliminate such "null spots" by moving your PEM-500T transmitter as little as 12-18 inches in any direction. If that is not convenient (e.g., because the PEM-500T is rackmounted), you can also use an optional remote antenna. Contact the NADY SYSTEMS Service Department (see pg.15) for information about remote antennas for the PEM-500T. After you move the transmitter or relocate a remote antenna, range walk the stage and other areas you will use in your performance to again check for consistent reception. You are now ready to use the PEM-500 system for wireless personal in-ear monitoring.

(Note: Due to the strong transmission power of the PEM-500T, you may experience compromised audio or static if the PEM-500R is too close to the antenna of the PEM-500T transmitter. Always operate the receiver at least 6 ft (2 m) away from the transmitter antenna.)

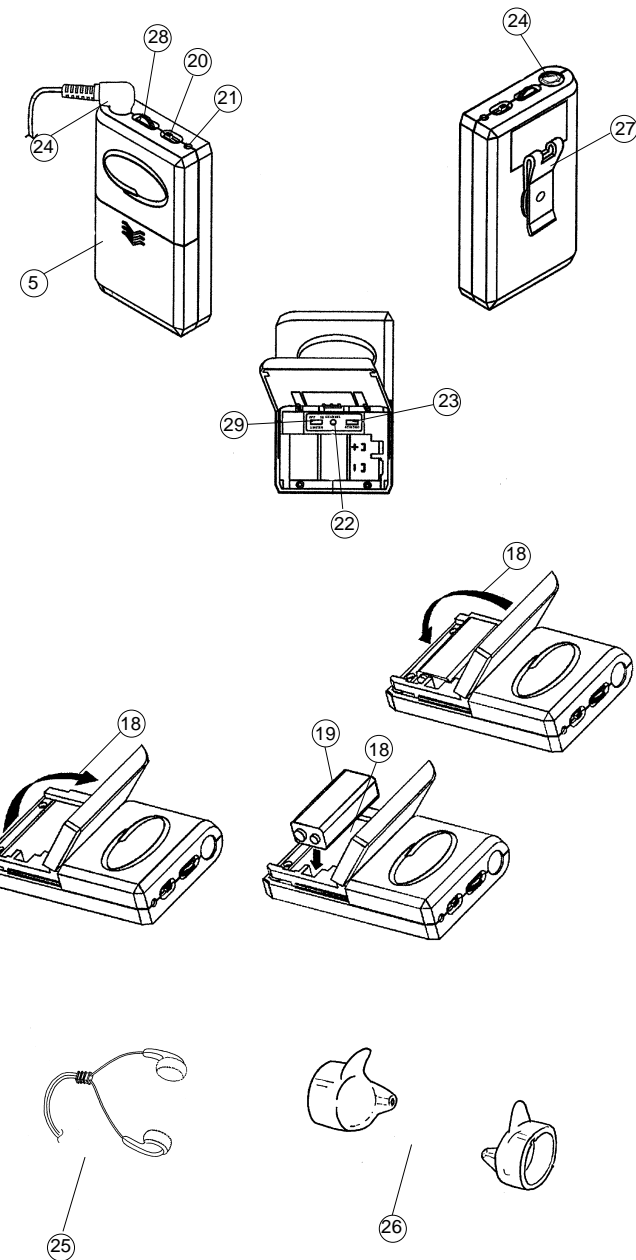

SPECIFICATIONS

Operating Frequency Range Modulation	564.000 to 574.300 MHz, country dependent Mono or stereo (MPX with pilot tone), FM: F3E +/- 60 KHz, nominal
Audio Frequency Response	50 ~ 12,000 Hz
T. H. D.	< 1%
Signal-to-Noise Ratio	> 80 dB, with proprietary companding noise reduction
Operating Range	Up to 300 feet typical (depending on site conditions)

PEM-500T Transmitter

RF Output Power	Max. 50 mW (country dependent)
L/R Audio Line Inputs	
Input impedance	600 Ω
Nominal Input Level	0 dBm
Max. Input Level	+6 dBm
Headphones Out Power	100 mW max. @ 32 Ω, 190 mW @ 16 Ω
Spurious Emission	> -55 dBc
Frequency Stability	+/- 100 PPM
Controls	Power ON/OFF, STEREO/MONO, and channel select switches; input level, headphones monitor volume controls
Connectors	1/4" stereo headphones monitor out, 1/4" TRS balanced mic input, balanced XLR L& R line input, and 2.1 mm barrel-type DC input jacks; BNC antenna socket
Indicators	Power ON LED; channel and 10-segment L/R audio input LED displays
Antenna	1/4 wave rigid detachable, BNC mount
Power Requirement	14V, 500mA, AC adapter supplied (UL/CSA approved 120VAC or CE approved 230VAC)
Dimensions	8.27" x 9.13" x 1.73" (210 x 232 x 44 mm)
Weight	2.98 lbs (1.35 Kg)

PEM-500R Receiver

Maximum Audio Output Level	20 mW
Minimum Audio	
Output Load Impedance	16 Ω
RF Sensitivity	2.5μV (-100 dB/12 dB SINAD)
Squelch Threshold	< -90 dB
Spurious Rejection	> 55 dBc
Audio Output Connector	3.5 mm Stereo (Tip=left, Ring=Right, Sleeve=ground)
Controls	Volume adjust; limiter ON/OFF, power ON/OFF, STEREO/MONO select switches; 16-position channel selector switch
Indicators	Two-color (red/green) 3-way unit ON/Signal/Low Battery LED
Power Requirements	9V alkaline battery
Current Drain	< 40 mA
Battery Life	Up to 6 hours, volume dependent
Antenna	Internal
Dimensions	4.2" x 0.9" x 2.6" (106 x 23 x 66 mm)
Weight	2.85 oz (80 Kg)

SERVICE

(U.S.) Should your Nady PEM-500 Wireless Personal In-Ear Monitor System require service, please contact the Nady Service Department via telephone at (510) 652-2411 or e-mail to service@nadywireless.com for a Return Authorization (R/A) Number and a service quote (if out of warranty). Make sure the R/A Number is clearly marked on the outside of the package that you send in and enclose a cashier's check or money order (if not prepaid with a credit card). Ship the unit prepaid to: Nady Systems, Inc., Service Department, 6701 Shellmound Street, Emeryville, CA 94608. Include a brief description of the problem you are experiencing.

The warranty card enclosed with this system contains additional valuable warranty and service information. Keep it in a safe place for possible future reference. Do not attempt to service this unit yourself as it will void the warranty.

(International) For service, please contact the Nady distributor in your country through the dealer from whom you purchased this product.

SERVICE FOR YOUR NADY AUDIO PRODUCT

(U.S.) Should your NADY AUDIO Product require service, please contact the Nady Service Department via telephone at (510) 652-2411 or e-mail at service@nadywireless.com.

(INTERNATIONAL) For service, please contact the NADY AUDIO distributor in your country through the dealer from whom you purchased this product.

DO NOT ATTEMPT TO SERVICE THIS UNIT YOURSELF AS IT CAN BE DANGEROUS AND ALSO WILL VOID THE WARRANTY.



NADY SYSTEMS, INC. • 6701 SHELLMOUND STREET, EMERYVILLE, CA 94608
Tel: 510.652.2411 • Fax: 510.652.5075 • www.nadywireless.com