

SERVICE

(U.S.) Should your Nady Wireless Microphone System require service, please contact the Nady Service Department via telephone at (510) 652-2411 or e-mail to service@nady.com for a Return Authorization (R/A) Number and a service quote (if out of warranty). Make sure the R/A Number is clearly marked on the outside of the package and enclose a cashier's check or money order (if not prepaid with a credit card). Ship the unit prepaid to: Nady Systems, Inc., Service Department, 6701 Shellmound Street, Emeryville, CA 94608. Include a brief description of the problems you are experiencing.

The warranty card enclosed with this system contains additional valuable warranty and service information. Keep it in a safe place for future possible reference. Do not attempt to service this unit yourself as it will void the warranty.

(International) For service, please contact the Nady distributor in your country through the dealer from whom you purchased this product.



WS-16U

16-Channel UHF PLL Synthesized Wireless System



Nady Wireless Systems are type accepted under FCC rules parts 90, 74 and 15. The device complies with RSS-210 of Industry & Science Canada. Operation is subject to the following two conditions: (1) this device may not cause harmful interference and (2) this device must accept any interference received, including interference that may cause undesired operation.



NADY SYSTEMS, INC.

6701 Shellmound Street • Emeryville, CA 94608 USA
Tel: 510.652.2411 • Fax: 510.652.5075 • www.nady.com

OWNER'S MANUAL

CONTENTS

INTRODUCTION	2
USING THIS MANUAL	2
SYSTEM FEATURES	3
WS-16U RECEIVER	4
HT-16U HANDHELD MICROPHONE TRANSMITTER	7
BT-16U BODYPACK MICROPHONE TRANSMITTER	8
SPECIFICATIONS	11
SERVICE	Back Cover

INTRODUCTION

Thank you for purchasing a Nady WS-16U UHF PLL Synthesized Microphone System and congratulations on your choice. The WS-16U is loaded with top professional operating features and is the best performance and price value available in UHF PLL Synthesized wireless systems.

USING THIS MANUAL

This booklet gives instructions for the operation of the WS-16U wireless, including handheld, instrument, lavalier, headmic and plug-in transmitter systems. Please read the instructions for your system completely before operating unit.

This manual will first list the features of the WS-16U and then will take you step by step to show you how to operate your new system. After reading the receiver instructions, turn to the section of the booklet that covers the type of transmitter used with your new system. Each section will give you detailed operating instructions. Also included in this manual are system specifications and servicing information.

SPECIFICATIONS

WS-16U OVERALL SYSTEM PERFORMANCE

RF Carrier Frequency	UHF, 16-frequency group in separate bands within 470-510 MHz
Frequency Stability	+/- 0.005%, PLL synthesized
Modulation	FM (F3E), \pm 50 KHz normal
Frequency Response	30 Hz~21 KHz, -3dB
Dynamic Range	120 dB
Total Harmonic Distortion	< 0.5%
Operating Range	Up to 250 ft. typical (depending on site conditions); Up to 500+ feet optimum line-of-sight

RECEIVER

Reception Mode	DigiTRU Diversity™ (Dual Antenna)
Unwanted Signal Rejection	>90 dB image and spurious
Squelch	External Control, Tone Key (45 KHz)
Controls	Power ON/OFF, Volume Control, Squelch Adjust, 16-Channel select
Connectors	DC in, 1/4"(6.3 mm) unbalanced phone jack output (360 mV/no load), XLR balanced output (24 mV/600 Ohm)
LED Indicators	Power ON, Diversity A/B, AF Audio LED bars + peak (5 segments)
Power Requirements	DC 19V @ 500mA, AC/DC adapter included
Dimensions (Max.)	1.75" x 5.5" x 8.1" (4.5 x 14 x 20.6 cm)
Weight	1.05 lbs (.48 kg)
Antennas	3.5" (9.0 cm), dual-folding antennas

TRANSMITTERS

RF Power Out	+14dBm (25mW) nominal
Harmonic & Spurious Emissions	< -45 dBc
Audio Inputs	BT-16U: 3.5mm locking mini-jack, switchable inputs: instrument, head-worn mic, or lavalier mic HT-16U: Integral Nady DM-10D neodymium dynamic cartridge
Controls	BT-16U: Power or Audio ON/OFF, Instrument/ Head-worn Mic/Lav Mic select, 16Ch elect, Input Level Adjust HT-16U: Power or Audio ON/OFF, 16-Ch select, Level Adjust
LED Indicators	BT-16U: Bicolor, Unit "ON" (green), Low Battery Alert (orange) HT-16U: Two LEDs, Unit "ON" (green), Low Battery Alert (red)
Battery	BT-16U: 2 x AAA Alkaline/NiMH HT-16U: 2 x AA Alkaline/NiMH
Battery Life	BT-16U: 3-4 Hours HT-16U: 7-8 Hours
Dimensions	BT-16U: 3.62" x 2.44"x 1.22"(9.2 cm x 6.2 cm x 3.1 cm) HT-16U: 2"x 9.25"(5.1 cm x 23.5 cm)
Weight	BT-16U: 3.1 oz (88 g) without battery HT-16U: 10.2 oz (290 g) without battery

Specifications subject to change without prior notice.

SYSTEM FEATURES

WS-16U RECEIVER

- Frequency agile rotary DIP switch with 16 user selectable channels in the wide open UHF band for interference-free use anywhere
- 120dB Dynamic Range — the quietest and best sounding UHF wireless available at any price
- 150-250 ft. typical operating range — up to 500+ ft. line-of-sight
- DigiTRU Diversity™ for maximum range and dropout protection
- Full LED indicators (including A-B/diversity and 5 segment AF level displays)
- Both 1/4" unbalanced and XLR balanced outputs
- Mute (squelch) adjust control
- Tone Squelch™ for locking out potential interference, and special circuitry for noiseless transmitter ON/OFF switching
- Half-rack receiver design with top folding dual antennas
- Unique snap-out side panel locking tabs for single receiver or dual receivers (side-by-side) optional rack mounting
- Externally powered by AC/DC power adapter

HT-16U HANDHELD MIC TRANSMITTER

- Sleek metal housing with internal antenna for optimum aesthetics and durable long life
- Features the Nady DM-10D unidirectional neodymium dynamic cartridge for optimum true sound, maximum feedback rejection and minimal handling noise
- Frequency agile rotary DIP switch with 16 user selectable channels
- Audio mute switch allows convenient audio muting with the transmitter "ON"
- Easy accessible level adjustment for optimum sound
- Status LED indicators for unit "ON" and for low battery alert "ON"
- Convenient, economical operation with two AA alkaline or NiMH batteries

BT-16U BODYPACK TRANSMITTER

- Internal selectable 3-way input select (headset mic, lavalier mic or instrument)
- Frequency agile rotary DIP-switch with 16 user selectable channels
- Audio mute switch for convenient audio muting with the transmitter "ON"
- Easy accessible input level adjustment for optimum sound (HM/LT)
- Bicolor LED status indicator for unit "ON" and for low battery alert "ON"
- Locking 3.5mm mini-jack provides secure connection for removable microphone or instrument cable
- Convenient, economical operation with two AAA Alkaline or NiMH batteries

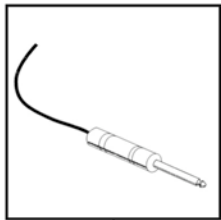
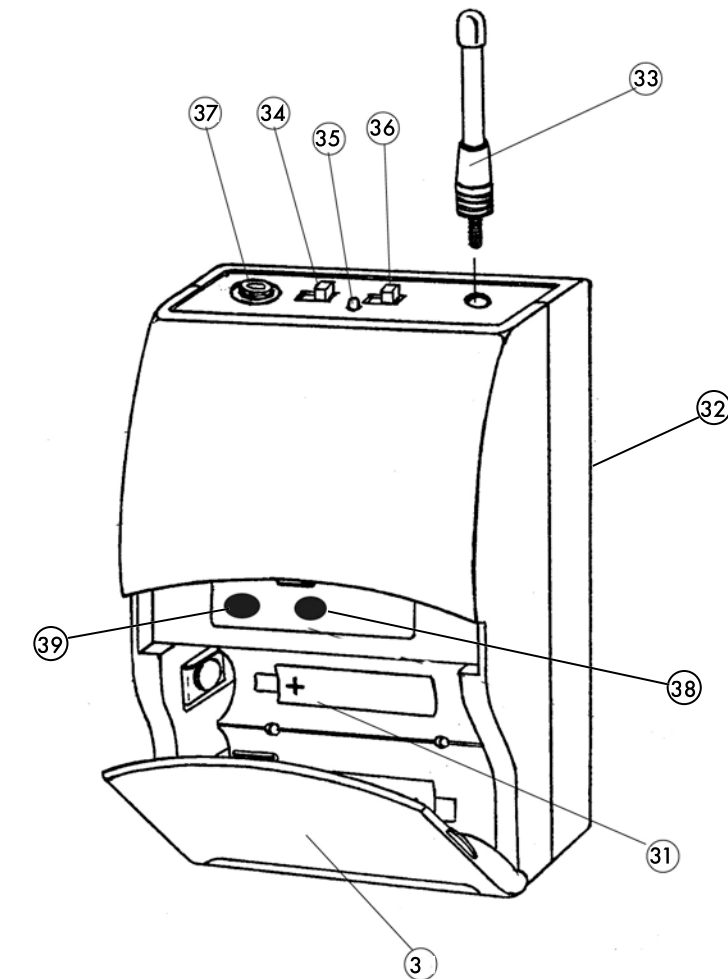

4

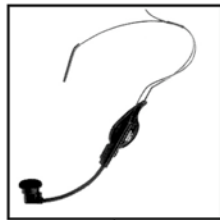

41

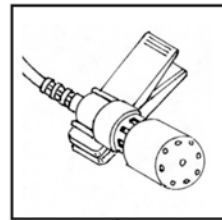

42

WS-16U RECEIVER

1. Rack mounting the Receiver

There are 2 options available for rack mounting the WS-16U receiver: singly or side-by-side with another WS-16U Series receiver.

- a. Single mounting: Remove the receiver **SIDE MOUNT CLIP (1)** from each side of the receiver (as shown) and slide in the optional **ERM-12 RACK EARS (2)**.
- b. Side-by-side double mounting: After removing the **SIDE MOUNT CLIPS (1)** from both WS-16U receivers, join the two receivers with the **EJC-2 JOINING CLIP (3)** and attach the **ERM-22 RACK EARS (4)** as shown. *(Note: Do not mount the receiver in a rack directly above an amplifier or other source of high heat — this could degrade the performance of the WS-16U. Always ensure adequate airflow and heat dissipation in any rack configuration.)*

2. Powering the Receiver

Plug the **18V AC/DC ADAPTER (5)** provided into the **DC INPUT JACK (9)** on the back of the receiver. Then plug the power supply into an AC outlet. Press the **POWER SWITCH (13)** once to turn on the receiver. The **POWER ON LED (12)** will now light and the receiver is operational.

3. Antennas

The WS-16U receiver is equipped with attached dual **FOLDING ANTENNAS (16)**. These should be extended fully to obtain maximum range. Optimal positions of the antennas are 45° from the receiver (at 90° from each other). For maximum range, it is always best to maintain a line of sight (no obstructions) between the receiver antennas and the transmitter at all times whenever possible.

4. Mute (Squelch) Adjustment

In normal operation, the **SQUELCH CONTROL (6)** should be set clockwise fully to the factory preset RF level (Max. Sens.). However, in areas of high RF activity, the squelch (or mute, as it is sometimes called) may need to be adjusted to compensate for the adverse conditions in a particular location. If, with the transmitter off, the receiver's A or B **DIVERSITY LED INDICATORS (14)** flicker or stay on, the squelch control should be turned counterclockwise until the A or B LEDs extinguish. When the squelch is properly adjusted, the A or B LEDs will only light when the system transmitter is turned on. Turning the squelch control too far counterclockwise will reduce the range, but yield a quieter squelch (mute) function. During operation, especially at ranges greater than 75 feet, the A or B LEDs may alternate briefly. This is normal unit's DigiTRU Diversity™ reception feature that ensures the received audio will not be interrupted. When both LEDs extinguish, the transmitter is out of range for that given location, and the user should move closer to the receiver to re-establish the radio link.

(Note: The BT-16U is supplied with a removable antenna. It should be operated with the supplied antenna all times. For optimum operating range, always maintain line-of-sight between the transmitter and the receiver whenever possible.)

*(Note: Scratchy noises can sometimes occur when some electric guitars with dirty pots or connections are used with any wireless system. Therefore, the supplied **INSTRUMENT CORD (40)** has a factory-installed capacitor inside the 1/4" plug. This capacitor provides first order filtering of the RF signal from the cord into the guitar and eliminates virtually all scratchy noises. Should your equipment still give you scratchy noises, we suggest these steps to eliminate them:)*

- a. Make sure all guitar volume and tone pots are clean and all contacts are solid as this is very important.
- b. A 47pf capacitor soldered across the hot to ground terminals of the guitar's volume and tone pots will provide extra filtering.

7. Microphone Use (with either a lavalier or head-worn microphone)

Secure the connection from the **HEADWORN (41)** or **LAVALIER MIC CORD (42)** by turning clockwise the slip ring on the plug into the transmitter to thread it on to the jack. To unplug, reverse the process. To use the lavalier mic, attach it at chest level. Do not place it too close to the mouth - a distance of about six inches usually works best. To use the head-worn mic, place it on the head and adjust the boom so that the mic is about one inch to the side of the front of the mouth. When ready to speak, slide the **AUDIO SWITCH (34)** to the ON position. Adjust the volume of the receiver as per the Audio Output Microphone Connection section of the above WS-16U receiver instruction

[Note: Observe care in selecting P.A. volume, transmitter location and speaker placement so that acoustic feedback (howling and screeching) will be avoided. Please also note the pickup pattern characteristics of the microphone selected. Omnidirectional mics pick up sound equally from all directions, and are prone to feedback if not used carefully. Unidirectional mics are more resistant to feedback, but pick up sound sources best that are directly in front of the mic. Also, mics that are farther from the sound source, such as lavalieres, require more acoustic gain and thus are more prone to feedback than close-source mics such as handheld or head-worn models that are used close to the mouth].

For optimum performance, an **INPUT LEVEL CONTROL (39)** is provided. Adjust the gain by turning the control with a small screwdriver. For lavalier mic use, it is recommended that the level be set at about 2/3 maximum. For head-worn mic use, it may be advisable to turn the gain down somewhat, depending on the volume levels expected. In either application, experiment and set for maximum possible gain without audible distortion on the high level peaks. *(Note: Turning down the gain too much can compromise the signal-to-noise and is not recommended.)*

BT-16U BODYPACK MICROPHONE TRANSMITTER

1. Open the hinged **BATTERY DOOR (30)** by pulling the door ears and lifting up. Insert two fresh AAA ALKALINE BATTERIES into the **BATTERY COMPARTMENT (31)**, observing the correct polarity. Close the **BATTERY DOOR (30)** by pushing it down at the middle between the door ears. Fresh alkaline batteries can last up to 5 hours in use, but in order to ensure optimum performance, it is recommended that the batteries be replaced after 3-4 hours of use.

2. The BT-16U is supplied factory preset for instrument, lavalier, or headset mic use. It can only be used for the specific preset application noted on the packaging box or audio will not be optimal — a muddy or distorted sound may result.

3. Select desired operating channel by turning the frequency agile rotary **DIP SWITCH (38)** to one of the sixteen channels. The slot on the switch shaft should match a number of the dial, which indicates the selected channel. (*IMPORTANT NOTE: The transmitter must be OFF when selecting a new channel. When selected, the transmitter will then be at the new selected channel when turned ON. If you attempt to change the channel when the transmitter is ON it will not change until the unit is turned OFF and ON again. This step must be repeated any time for selecting a new channel.*)

4. The BT-16U is provided with a 3.5 mm **LOCKING JACK (37)** for connecting the audio input selected. Connect either the **INSTRUMENT CORD (40)** or the **HEADWORN MIC (41)** or **LAVALIER MIC CORD (42)** as desired according to the unit type supplied. To secure the connection, turn the slip ring on the plug clock wise to thread it on the jack. To unplug, reverse the process. Slip the transmitter into a pocket or **CLIP (32)** it onto your clothes or instrument strap (if using the BT-16U as an instrument transmitter).

5. Turn on the BT-16U by sliding the **AUDIO SWITCH (34)** to the OFF position first then slide the **POWER SWITCH (36)** to the ON position. The Bi-Color LED INDICATOR (35) will stay on (GREEN) indicating usable battery strength and the transmitter is on. In the case of dead or low batteries, the LED will either not go on at all or will stay on (ORANGE) continuously, indicating that the batteries should be replaced with fresh ones. To preserve battery life, turn the transmitter off when not in use. The A or B **DIVERSITY LED INDICATORS (14)** on the WS-16U receiver should now be lit, indicating a received signal from the transmitter.

6. Instrument Use

Secure the connection from the **GT CABLE (40)** by turning the slip ring on the plug into the transmitter clockwise to thread it on the jack. To unplug, reverse the process. Plug the 1/4" phone plug into the instrument. When ready to play, slide the **AUDIO SWITCH (34)** to "ON" position or to mute the audio, turn it to OFF again. Adjust the volume of the receiver as per the Audio Output Instrument Connection section of the above WS-16U receiver instruction. (*Note: The **INPUT LEVEL CONTROL (39)** is deactivated and not used when the BT-16U is in INSTRUMENT mode. Levels should be adjusted with the volume control of your instrument.*)

5. Channel Selection

Turn the frequency agile rotary **DIP switch (11)** to one of the sixteen channels. The slot on the switch shaft should match a number on the dial, which indicates the selected channel.

6. Audio Level and Peak LED Indicator (AF)

The WS-16U receiver is equipped with a five segment **LED AF LEVEL DISPLAY (15)**. Occasional flickering to the top AF Peak LED indicator on loud inputs to the transmitter is normal. If all LED lights continuously, or stay lit continuously, turn down the **INPUT LEVEL CONTROL** on the transmitter, or noticeable distortion may result.

7. Connecting the Audio Output

The WS-16U receiver provides both a fixed mic level **BALANCED MIC AUDIO OUTPUT XLR (7)** and an adjustable line level **AUX AUDIO OUTPUT 1/4" jack (10)**.

(*Note: As when making any connection, make sure the amplifier or mixing board volume is at the minimum level before plugging in the receiver to avoid possible sound system damage.*)

Receiver Connection

(Using the BT-16U transmitter with either a head-worn or lavalier microphone or the HT-16U handheld microphone transmitter) For microphone use, either the **BALANCED MIC AUDIO OUTPUT XLR (7)** or the 1/4" line level **AUX AUDIO OUTPUT (10)** can be used. The XLR output is set at a non-adjustable microphone level, similar to hardwired mic levels. Plug an XLR connector into the XLR output socket on the rear of the unit and plug the other end into your amplifier or mixing board. Make sure the phantom power on your mixing board is turned off and the volume is turned down when making connections. For your convenience, the XLR output level is preset at the factory and is not adjustable with the receiver volume control.

For instrument, the 1/4" **AUX AUDIO OUTPUT (10)** socket could be used and follow the instructions for the Instrument Connection (above), except start the receiver volume at 1/2 MAX and adjust until the volume level is optimal. If the volume control is set too high, you may overload your mixer or amp.

HT-16U HANDHELD MICROPHONE TRANSMITTER

1. Installing batteries by unscrew counterclockwise the **BATTERY COMPARTMENT COVER (28)** and remove, exposing the **BATTERY HOLDER (26)**. Insert two fresh **AA ALKALINE BATTERIES (27)**, observing the correct polarity as marked, and screw the cover back on to the microphone. Make sure the cover is screwed clockwise completely. Fresh alkaline batteries can last up to 10 hours in use, but in order to ensure optimum performance, it is recommended that you replace the batteries after every 7-8 hours of use.

3. Select Channel by turning the frequency agile rotary **DIP SWITCH (20)** to one of the sixteen channels. The slot on the switch shaft should match a number of the dial, which indicates the selected channel. *(IMPORTANT NOTE: The transmitter must be OFF when selecting a new channel. When selected, the transmitter will then be at the new selected channel when turned ON. If you attempt to change the channel when the transmitter is ON it will not change until the unit is turned OFF and ON again. This step must be repeated any time for selecting a new channel.)*

3. Turn on the HT-16U by sliding the **AUDIO SWITCH (21)** to the OFF position first. Then slide the **POWER SWITCH (22)** to the ON position. The **TX LED INDICATOR (23)** will stay on and the **BATTERY INDICATOR LED (24)** will stay off, indicating usable battery strength. In the case of a dead or low battery, the **BATTERY LED INDICATOR (24)** will either not go on at all or will stay on continuously, indicating that the batteries should be replaced with fresh ones. To preserve battery life, turn the transmitter off when not in use.

4. The microphone is now ready to use. The **A or B DIVERSITY LED INDICATORS (14)** on the WS-16U receiver should now be lit, indicating a received signal from the transmitter. When ready to speak, slide the **AUDIO SWITCH (21)** to the ON position or to mute the audio, turn it to OFF again. This switch mute the audio during use, can be turned on/off again. Adjust the volume of the receiver as per the Audio Output Microphone Connection section of the above WS-16U receiver instructions. *[Note: Observe care in selecting P.A. volume, transmitter location and speaker placement so that acoustic feedback (howling or screeching) will be avoided. Note: The windscreen of the HT-16U functions as a built-in antenna. For proper operation, never remove the windscreen during use, or exchange with another type. For optimum range maintain line-of-sight between the transmitter and the receiver whenever possible. Holding the microphone tightly, bridging across the windscreen and mic tube, will also lessen range. Hold by the mic tube housing only for optimum operation.]*

5. For optimum performance, an **INPUT LEVEL CONTROL (25)** is provided. Adjust the gain by turning the control with a small screwdriver. It is recommended that the level be set at about 1/2 maximum. Experiment and set for maximum possible gain without audible distortion on the high level peaks. *(Note: Turning down the gain too much can compromise the signal-to-noise and it is not recommended.)*

