



U-41 QUAD

*Four Discrete Channel UHF
Wireless Microphone System*



OWNER'S MANUAL

TABLE OF CONTENTS

TABLE CONTENTS.....	2
INTRODUCTION.....	2
USING THIS MANUAL.....	2
SYSTEM FEATURES.....	3
U-41 QUAD RECEIVER OPERATION INSTRUCTION.....	4
UH-4 HANDHELD TRANSMITTER.....	7
UB-4 BODYPACK TRANSMITTER.....	8
CAUTIONS AND TROUBLESHOOTING.....	11
TIPS.....	12
SPECIFICATIONS.....	13
FREQUENCY PLAN.....	13
SERVICE INFORMATION.....	14
WARRANTY.....	15

INTRODUCTION

Thank you for choosing the Nady U-41 QUAD wireless system, we know you will be very pleased with its performance and features. The Nady U-41 QUAD is a professional 4-channel UHF wireless system which offers the clearest, most natural sound available in wireless today. The Nady U-41 QUAD delivers four discrete channels in the 902-928MHz and 944-952MHz bands for interference-free performance in any application or locale. It also features Nady's proprietary companding and low noise circuit for an industry best 120dB dynamic range.

USING THIS MANUAL

This booklet provides information regarding the use of the U-41 QUAD wireless systems: The U-41 QUAD wireless microphone receiver, the UH-4 Handheld Microphone transmitter and the UB-4 bodypack microphone transmitter. It includes a description of features and a step-by-step guide to operation of the unit. This manual should answer any questions you may have about the operation and servicing of your U-41 QUAD wireless system.

SYSTEM FEATURES

U-41 QUAD Receiver

- Four discrete UHF wireless receivers in a single rugged 19" 1U, all-metal rack mount housing
- Back panel Balanced XLR mic level output, Unbalanced 1/4" jack line level sum output with separate volumes, and external adjustable mute control for each channel
- Front panel LED display indicates TX on and AF levels bar graph for each channel and dual removable antennas
- Nady's exclusive patented companding circuitry and highest quality audio for an unsurpassed UHF performance with 120dB dynamic range
- Operates on UHF frequencies in the 902-928MHz and 944-952MHz bands
- Tone Squelch™ circuitry for protection from RF interference
- Externally powered with DC adapter (16.5VDC/0.4A) included

UH-4 Handheld Microphone Transmitter

- Nady DM-10D neodymium cartridge delivers transparent vocals, maximum feedback rejection and minimal handling noise
- OFF/MUTE/ON switch for ease of use
- Unique screw-on battery compartment for quick pop-in battery replacement—uses standard 9V alkaline battery
- Single LED indicator flashes once for unit on; lights steady for low battery alert
- Input level control for optimum sound adjustment
- Rugged ABS housing with integral antenna

UB-4 Bodypack Transmitter

- Compact bodypack with screw on jack for instrument or lavalier microphone input
- OFF/MUTE/ON switch for ease of use
- Unique sliding battery compartment for quick pop-in battery replacement—uses standard 9V alkaline battery
- Single LED indicator flashes once for unit on; lights steady for low battery alert
- Input level control for optimum sound adjustment (LT and HM)
- Rugged ABS housing with external antenna

U-41 QUAD RECEIVER

Rack-mounting the Receiver

The Nady U-41 QUAD UHF receiver has built-in brackets for rackmounting. Simply attached the unit to the rack and tighten the unit with screws.

(Note: Do not mount the receiver in a rack directly above an amplifier or other source of high heat. This could degrade the performance of the U-41 QUAD. Always ensure adequate airflow and heat dissipation in any rack configuration.)

Antennas

Install antennas by connecting the two **ANTENNAS (1)** included with your system to the two **RF BNC CONNECTORS (2)** located on the left and right front of the U-41 QUAD receiver.

The optimal positions of the antennas are 90 degrees from the receiver pointing up position. For maximum range, it is always best to maintain a line of sight (no obstructions) between the receiver antennas and the transmitter at all time whenever possible.

Powering the Receiver

Power the receiver by plugging the provided **AC ADAPTOR (3)** (16.5VDC/0.4A) plug into the **DC INPUT JACK (4)** on the back of the receiver. Then plug the adapter into an AC outlet.

(Note: Any 16.5VDC source with 400mA capacity can also be used.) Turn **VOLUME CONTROLS (5)** of all channels counterclockwise to minimum settings. Once the receiver is connected to a power source, press the **POWER SWITCH (6)** to the ON position. The **TX INDICATOR LEDS (7)** on the front panel of the receivers will not light up at this time, until one or more of the four channels is receiving a signal from your system's transmitters.

To turn OFF, press the **POWER SWITCH (6)** to the OFF position. The receiver will be off.

Adjusting Mute

In normal operation, each channel's **MUTE CONTROL (8)** should be turned clockwise fully to the factory preset RF level of 1uV for maximum sensitivity. Doing so sets each receiver for maximum range. However, in case of high RF activity, the mute should be adjusted. If, with a transmitter turned off, its corresponding LED on the receiver front panel flickers or stays on, the mute control of the corresponding channel should be turned counterclockwise until the LED extinguishes. For each of the four channels, when the mute is properly adjusted, the corresponding LED will light only when the system's transmitter is turned on.

Turning the mute clockwise too far will result in reduced range, but yield a quieter signal during dropout or at the end of the operating range.

Audio Level and Peak LED indicator

The U-41 QUAD receiver is equipped with a 5-segment **LED AF LEVEL (9)** display for each channel. The red LED on the right of these displays is the audio peak indicator. Note that the peak red LED will light with a strong audio signal from the transmitter. Occasional flickering of the peak LED on loud input signals to the transmitter is normal. However, if the peak LED lights continuously, the volume into the transmitter should be decreased or audio distortion may result.

Connecting Audio Outputs

The U-41 QUAD audio output stage of each channel is configured for XLR balanced microphone fixed level, with an output impedance of 600 ohms, to accommodate both balanced and unbalanced mics. The **XLR OUTPUTS (10)** are preset at the factory and are not adjustable with the receiver volume controls. For each channel you wish to use, insert an audio cord with a female XLR plug into its audio jack on the back of the receiver. Plug the other end cord into your amplifier, effects or mixing board. The volume level of each receiver should be adjusted by the mixing board.

U-41 QUAD RECEIVER

The U-41 QUAD also has a summed adjustable line level unbalanced output for all channels (MIX). To use, just plug an audio cable with a 1/4" mono plug into the MIX out and plug the other end to your amplifier or mixing board. Turn **VOLUME CONTROLS (5)** on the U-41 QUAD UHF receiver clockwise to near full gain. Adjust each channel's volume up or down so that no audio distortion is present when the amplifier or mixer is set at their usual levels.

Your U-41QUAD is now operational and ready to use. Now that you have completed the above step, proceed to instructions for the UH-4or UB-4 transmitter included with your system.

Additional Features — Tone Squelch™

The U-41 QUAD receiver and transmitters feature Nady's Tone Squelch™ circuit. Nady offers Tone Squelch™ for professional uses and anyone who needs advanced protection against RF interference during a recording, performance, or presentation.

This feature is strongly recommended for situations where the transmitter is turned on or off during use. With Tone Squelch™, an unwanted signal on the same operating which may enter your inactive receiver will not be amplified by your connected equipment even if the receiver is left on with the transmitter(s) off.

Thus Tone Squelch™ prevents a pop or disruptive noise from your sound system. The receiver detects a specific tone code signal from your transmitter, which unlocks your receiver's audio. In this manner only your own modulated signal can then be heard. (The receiver has an internal Tone Squelch™ defeat feature. Contact your Nady dealer or Nady Systems Customer Service for details.)

Note:

- *The noise from the unused channels are normal and do not indicate a defective channel. This noise is caused by the mixing of the RF waves.*
- *To prevent possible undesired noise from the unused channel during use, keep the volume controls of unused channels, (corresponding transmitter off) turned to minimum counter clockwise or turned off in the amplifier or the mixer. The audio should only be "live" if the transmitter is on.*
- *As when making any connection, make sure the amplifier or mixing board volume is at the minimum level before plugging in the receiver to avoid possible sound system damage.*
- *For a GT system, use the AF OUT outputs connect directly to your own system. The system output is approximately +4dB higher than a direct cord-to-amp connection.*
- *Only one transmitter can be used with one receiver. It is not possible to use two transmitters on the same frequency and mix the output of these transmitters into one wireless receiver. The U-41 QUAD receiver has 4 discrete receivers built in so can be used with 4 transmitters on the same frequencies as these 4 receivers.*

U-41 QUAD RECEIVER

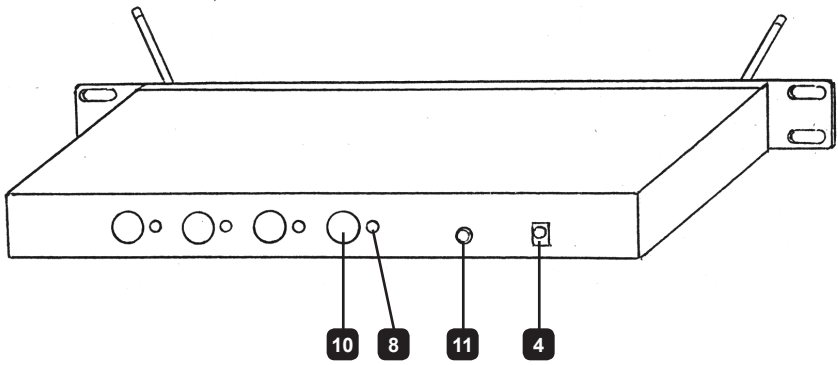
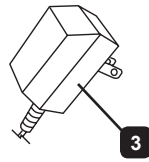
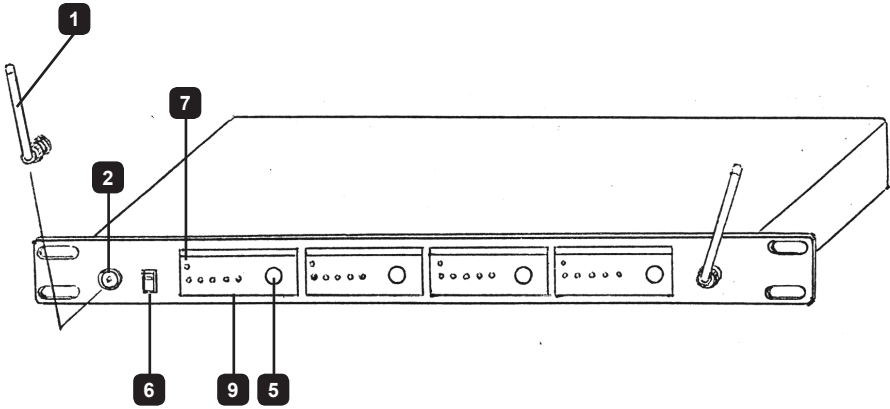

UH-4 HANDHELD TRANSMITTER

Transmitters set up

The UH-4 transmitter requires a single 9V battery to operate. To open the battery compartment, unscrew the **BATTERY COVER (16)** with a counter-clockwise turn and remove the cover, exposing the **BATTERY HOLDER (17)**. Insert a fresh 9V battery according to the correct polarity as indicated on the transmitter body. Screw the battery cover back onto the microphone. Make sure the cover is screwed on completely. Fresh alkaline batteries can last for up to 10 hours of operation, but in order to ensure optimum performance, it is recommended that the batteries should be replaced after 6-8 hours of use.

Transmitter Operation

To turn transmitter on, slide the **OFF/STANDBY/ON SWITCH (18)** to the STANDBY position first (transmitter on, audio muted) or the ON position (transmitter and audio both on). The **LOW BAT LED (19)** will give a single flash, indicating usable battery strength. In case of dead or low battery, the LED will either not go on at all or will stay on continuously. During use, if the low battery/LED stays on continuously, it is indicating that the battery should be replaced with a fresh one. To preserve battery life, turn the transmitter off when not in use.

Receiver Volume Controls Adjust

The volume controls work only for the 14" sum output (MIX). Turn the corresponding **VOLUME CONTROLS (5)** on U-41 QUAD UHF receiver being used clockwise to near full gain. Adjust Volume up or down so that no audio distortion is present when amplifier or mixer is set at their usual levels. At full gain, the system gain for HT is approximately +20dB higher than a direct line to amp connection. If the fixed level **XLR OUTPUTS (10)** are used, the volume level of each receiver should be adjusted by the mixer to which the U-41 QUAD UHF receiver is connected.

The microphone is ready to use. The corresponding TX LED indicator on the U-41 QUAD UHF receiver should now be lit.

Level Trim Adjust

For optimum performance, an **INPUT LEVEL CONTROL (20)** is provided for the transmitter. Adjust the microphone gain by inserting a small slot-headed screwdriver through the adjustment hole, located on the topside of the battery compartment, under the compartment cover. Factory setting is 1/2 full. This is a setting to be used in most typical close microphone applications. Depending on the average distance between vocalist's mouth and microphone, you can adjust the level for your application. Set for maximum possible gain and headroom without noticeable distortion of the high level peaks. It is recommended that the level be set at about 1/2 maximum. Experiment and set for maximum possible gain without audible distortion on the high level peaks.

(Note: Turning down the gain too much can compromise the signal-to-noise and it is not recommended.)

The transmitter is now ready to use. The TX LED indicator on the corresponding receiver should now be on, indicating a received signal from the transmitter. When ready to speak, slide the switch to the ON position. Adjust the volume of the receiver as outlined in the *Receiver Operating Instructions* section: *Connecting Audio Outputs*.

Notes:

- The battery compartment on the UH-4 functions as a built-in antenna. For proper operation, it should not be covered by the hand or touched during operation.
- Observe care in selecting P.A. volume, transmitter location and speaker placement so that acoustic feedback (howling or screeching) will be avoided.

UH-4 HANDHELD TRANSMITTER

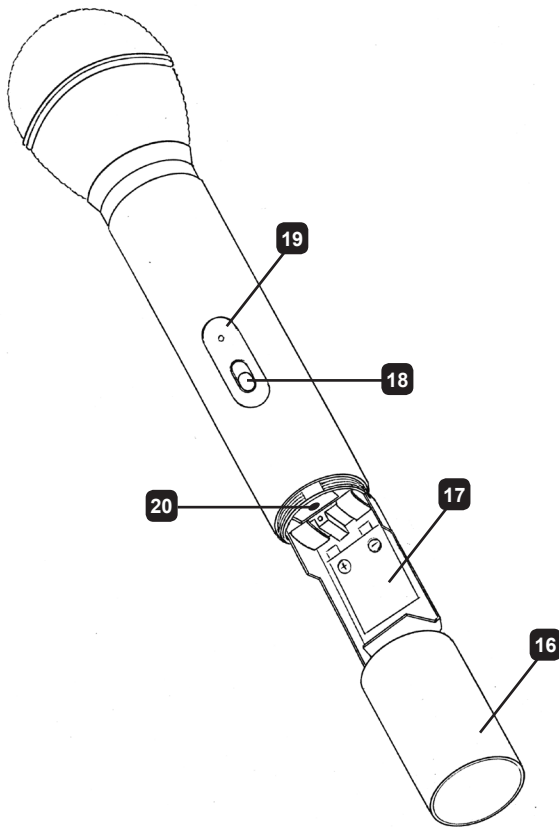

UB-4 BODYPACK TRANSMITTER

Transmitters set up

The UB-4 transmitter requires a single 9V battery to operate. To open the battery compartment, snap open the **BATTERY DOOR COVER (21)**, exposing the **BATTERY HOLDER (22)**. Insert a fresh 9V battery according to the correct polarity as indicated on the transmitter body. Snap the cover back onto the bodypack. Make sure the cover is secured completely. Fresh alkaline batteries can last up to 10 hour of operation, but in order to ensure optimum performance, it is recommended that the batteries should be replaced after 6-8 hours of use.

Input Connection and Input Selector Switches

The UB-4 is provided with a **3.5MM LOCKING JACK (23)** for connecting the audio input selected. Connect either the **INSTRUMENT CORD (24)**, or the **HEADWORN MIC (25)**, or **LAVALIER MIC (26)** as desired, according to the input selected. (Note: Use only the input audio source as per the setting selected by the Input Selector Switch or the audio will not be optimal- a muddy or distorted sound may result.) To secure the connection, turn the slip ring on the plug clockwise to thread it on the jack. To unplug, reverse the process. Slip the transmitter into a pocket or clip it onto you cloth or instrument strap (if using the UB-4 as an instrument transmitter.)

UB-4 BODYPACK TRANSMITTER

The UB-4 is equipped with two **INPUT SELECTOR SWITCHES (27)** located under the cover on the circuit board for selecting the type of audio input you will be supplying to the transmitter. Select from the choice of three positions: INSTRUMENT (for guitar, bass, etc.)/ HEADWORN MIC/ LAVALIER MIC. (G/H/L).

There are two switches, one with selectable position G, H, L and the other with G, HL.

To select inputs: (see chart on page 10)

A. Instrument — both switches to “G”

B. Headworn Mic — set one switch to “HL” and the other to “H”

C. Lavalier Mic — set one switch to “HL” and the other to “L”

Transmitter Operation

To turn transmitter on, slide the **OFF/STANDBY/ON SWITCH (28)** to the STANDBY position first (transmitter on, audio muted) or the ON position (transmitter and audio both on). The **LOW BAT LED (29)** will give a single flash, indicating usable battery strength. In case of dead or low battery, the LED will either not go on at all or will stay on continuously. During use, if the low battery/ LED stays on continuously, it is indicating that the battery should be replaced with a fresh one.

To preserve battery life, turn the transmitter off when not in use.

Receiver Volume Controls Adjust

The volume controls adjust only the 1/4” sum output. Turn **VOLUME CONTROLS (5)** on the U-41 receiver clockwise to near full gain. Adjust Volume up or down so that no audio distortion is present when amplifier or mixer is set at their usual levels. At full gain, the system gain for LT or HM is approximately +20dB (+4dB for GT) higher than a direct line-to-amp connection. If the fixed level **XLR OUTPUTS (10)** are used, the volume level of each receiver should be adjusted by the mixer to which the U-41 receiver is connected.

Level Trim Adjust

For optimum performance, an **INPUT LEVEL CONTROL (30)** for LT/HM is provided. Adjust the microphone gain by inserting a small slot-headed screwdriver to the adjustment knob, located on the top side of the transmitter unit, next to the mic input jack. Factory setting is 1/2 full. This is a setting to be used in most typical close microphone applications. Depending on the average distance between vocalist’s mouth and microphone, you can adjust the level for your application. Set for maximum possible gain and headroom without noticeable distortion of the high level peaks. It is recommended that the level be set at about 1/2 maximum. Experiment and set for maximum possible gain without audible distortion on the high level peaks.

(Note: Turning down the gain too much can compromise the signal-to-noise and it is not recommended.)

The transmitter is now ready to use. The TX LED indicator on corresponding receiver should now be on, indicating a received signal from the transmitter. When ready to speak, slide the switch to the ON position. Adjust the volume of the receiver as per in the receiver operating instruction section.

Notes:

- The transmitter has an external flexible wire antenna. For proper operation, it should not be covered or touched during operation.
- Observe care in selecting P.A. volume, transmitter location and speaker placement so that acoustic feedback (howling or screeching) will be avoided.

UB-4 BODYPACK TRANSMITTER

INPUT SELECTOR SWITCHES											
Instrument	<table border="0"> <tr> <td>HL</td> <td>█</td> <td>█</td> <td>█</td> <td>█</td> </tr> <tr> <td>G</td> <td>█</td> <td>█</td> <td>█</td> <td>█</td> </tr> </table>	HL	█	█	█	█	G	█	█	█	█
HL	█	█	█	█							
G	█	█	█	█							
Headworn	<table border="0"> <tr> <td>HL</td> <td>█</td> <td>█</td> <td>█</td> <td>█</td> </tr> <tr> <td>G</td> <td>█</td> <td>█</td> <td>█</td> <td>█</td> </tr> </table>	HL	█	█	█	█	G	█	█	█	█
HL	█	█	█	█							
G	█	█	█	█							
Lavalier	<table border="0"> <tr> <td>HL</td> <td>█</td> <td>█</td> <td>█</td> <td>█</td> </tr> <tr> <td>G</td> <td>█</td> <td>█</td> <td>█</td> <td>█</td> </tr> </table>	HL	█	█	█	█	G	█	█	█	█
HL	█	█	█	█							
G	█	█	█	█							

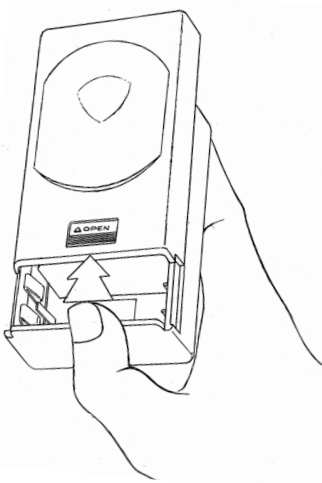
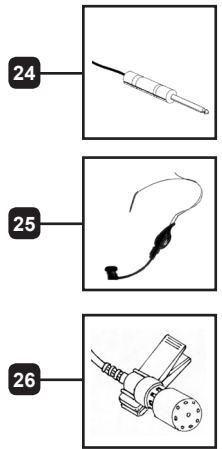
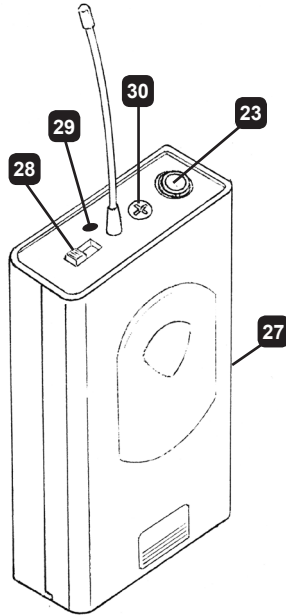

Opening Battery Compartment

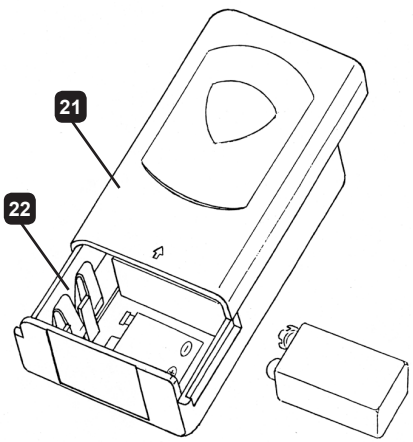

CAUTIONS AND TROUBLESHOOTING

Feedback

Observe care in selecting P.A. volume, transmitter location and speaker placement so that the acoustic feedback (howling and screeching) will be avoided. Please also note the pickup pattern characteristics of the microphone selected. Omni directional mics pick up sound equally from all direction, and are prone to feedback if not used carefully. Unidirectional mics are more resistant to feedback. However, pick up sound source best that are directly in front of the mic. Also mics that are farther from the sound source, such as lavalier, required more acoustic gain and thus are also more prone to feed back than close-source mics such as handheld or headworn models that are used close to the mouth.

Microphone Damage

Headset and lavalier mic users, note that the microphone element can easily be destroyed by the buildup of salts and minerals from perspiration and saliva. It is good practice to put a windscreen on the mic at all time to protect it.

No Audio

If you not getting audio through the system, carefully recheck all setup procedures. The receiver and transmitter must be on the same RF channel (frequency).

RF Interference

If you encounter receiving interference (from other than an operating TV station), often it can be overcome by adjusting the receiver 's MUTE (squelch) control. Please note that wireless frequencies are shared with other radio services. According to FCC regulations, wireless microphone operations are unprotected from interference from other licensed operations in the band. If any interference is received by any Government or non-government operation, the wireless microphone must be cease operation or change frequencies. The above statement is valid only for use in the U.S.A.

TIPS

- The receiver antennas should be kept away from any metal surface.
- If the Volume Control of the receiver is set too high, it may over-drive the input of the mixer, causing distortion. Conversely, if the output is set too low, the overall signal to noise ratio of the system may be reduced. Adjust the output level of the receiver such that highest sound pressure level going into the microphone causes no input overload in the mixer, and yet permits the mixer level control to operate in the normal range (not too high and not too low). This provides the optimum signal to noise for the entire system.
- Before inserting the batteries, please make sure that they are inserted according to the correct polarity.
- Use only brand new alkaline batteries. Do not use “general purpose” batteries. When batteries are weak, replace the batteries altogether at the same time.
- Position the receiver such that it has the least possible obstructions between it and the transmitter. Line of sight is best!
- The transmitter and the receiver should be as close as possible but not less than 3 feet (1 meter).
- For the best operation, the receiver should be placed at least 3 feet (1 meter) above the ground and 3 feet (1 meter) away from a wall or metal surfaces. The transmitter should be also at least 3 feet (1 meter) from the receiver. Keep antenna away from noise source such as motors, automobiles, neon light, signal processor, computer, as well as large metal objects.
- A receiver cannot receive signal from two or more transmitters simultaneously. The U-41 has two receivers so can be operated with two transmitters only on the same frequencies.
- Turn the transmitter off when it is not in use. Remove the batteries if it is not to be used for a long period.

Note: Scratchy noises can sometime occurs when some electric guitars with dirty pots or connections are used with any wireless system. Therefore, the supplied capacitor provides first order filtering of the RF signal from the cord into the guitar and eliminates virtually all scratchy noises. Should your equipment still give you scratchy noises, we suggest these steps to eliminate them:

- a. Make sure all guitar volume and tone pots are clean and all contacts are solid—this is very important.*
- b. A 47pF capacitor soldered across the pot to ground terminal of the guitar's volume and tone pots will provide extra filtering.*

SPECIFICATIONS

OVERALL SYSTEM SPECIFICATIONS

Frequency Response	30Hz-18kHz, -3dB
Dynamic Range	120dB
Harmonic Distortion	<0.5% THD, normal
RF Carrier Frequencies	Factory installed channels between 902-928MHz and 944-952MHz
Frequency stability	+/-0.005% Crystal Controlled
Modulation	FM +/-20kHz normal, +/-50kHz maximum
TSQ Frequency	32.768kHz
Operating Range	250 feet normal, 500+feet max line of sight

RECEIVER SPECIFICATIONS

Controls	Power ON/OFF buttons, Volume/Mute Controls
Audio Output Level	Unbalanced Sum output: 360mV variable level Balanced outputs; +/-24mV fixed level
Connectors	Balanced: XLR. Unbalanced: 1/4" TS DC in: 2.1mm barrel type
Indicators	Power On, TX and AF LEDs
Mute Threshold	-65dBm to -95dBm (adjustable)
Image Rejection	70dB, minimum
Power Requirement	16.5VDC/0.4A
Antennas	4.0" (10.2 cm) Dual telescopic antennas
Dimensions	17" x 6.25" x 1.75 [W / D / H] (43.18 cm x 15.88 cm x 4.45 cm) [W / D / H]
Weight	4.10 lbs (1.86 Kg)

TRANSMITTER SPECIFICATIONS

Models Available	UH-4 Handheld and UB-4 Bodypack transmitters
RF Output Power	+14dBm (25mW normal), +17dBm (50mW maximum allowed by FCC)
Harmonic/spurious	-50dBc normal
Antenna Type	UH-4: Integral. UB-4: External permanent attached
Controls	Transmitter ON/Mute/OFF switch, Audio Input level control (LT/HM),
Audio Input Levels	UH-4: 24mV, UB-4: 225mV (Instr.), 310mV (HM), 75mV (Lav.)
Input Impedance	UH-4: 3.3k Ω , UB-4: 500k Ω (Instr.), 2k Ω (HM/Lav.)
Connector	UB-4: 3.5mm locking jack
Indicator	Power and Low Battery LEDs
Battery Type	9V alkaline or rechargeable battery
Battery Life	8-10 Hours normal
Dimensions	UH-4: 9.5" x 2.0" [L / Dia.] (24.13 cm x 5.08 cm) UB-4: 2.5" x 4.25" x 1.0 [W / D / H] (6.35 cm x 10.80 cm x 2.45 cm)
Weight (w/o batteries)	UH-4: 6.6 oz (187 g), UB-4: 3.1 oz (88 g)

Specifications and design subject to change for improvement purposes without prior notice.

FREQUENCY PLAN

Four UHF frequencies

Channel 14: 906.000MHz
Channel 16: 911.700MHz
Channel 10: 944.200MHz
Channel 12: 947.300MHz

SERVICE INFORMATION

In the U.S. If you are experiencing operational problems with your system, please refer to the Support page at www.nady.com for assistance. Should your wireless system require service, please contact the Nady Service Department at (510) 652-2411 for a Return Authorization (R/A) Number and service quote (if out of warranty). Make sure the R/A Number is clearly marked on the outside of the package that you are returning.

If your unit is out of warranty, please enclose a cashier's check or money order (or pay by credit card) per instructions by the Nady Service Department. Ship your unit prepaid to: Nady Systems, Service Department, 6701 Shellmound Street, Emeryville, CA 94608. Include a brief description of the problem you are experiencing. For service of a unit under warranty, please follow the instructions in the following section.

Outside the U.S. For service or warranty matters please contact the Nady distributor in your country through the dealer/store from which you purchased this product.

Do not attempt to service this unit yourself as it can be dangerous and will also void the warranty.

ONE-YEAR LIMITED WARRANTY

Nady Systems, Inc. warrants to the original consumer purchaser that the above unit is free from any defects in material or workmanship for a period of one year from the date of original retail purchase. If any such defect is discovered within the warranty period, Nady Systems, Inc. will repair or replace the unit free of charge, subject to verification of the defect or malfunction upon return to Nady Systems.

To the extent permitted by law, any applicable implied warranties, including warranties of merchantability and fitness are hereby limited to one year from the date of purchase. Consequential or incidental damages resulting from a breach of any applicable express or implied warranties are hereby excluded. This warranty is in lieu of all other agreements and warranties, general or special, express or implied and no representative or person including a Nady dealer, agent, or employee is authorized to assume for us any other liability in connection with the sale or use of this Nady Systems' product.

Whereas some states do not allow limitations on how long implied warranties last, and do not allow exclusion of incidental or consequential damages, the above limitations and exclusions may not apply to you. This warranty gives you specific legal rights and you may also have other rights which may vary from state to state.

This warranty is subject to the following conditions:

- 1) This system must have been purchased from an authorized Nady dealer and all warranty service must be performed by Nady's service department. Any service not performed by Nady will automatically void this warranty.
- 2) Items not covered: physical damage resulting from improper handling of the unit in transit from the factory by the shipper (Nady Systems is not responsible for such damage and all such claims must be made against the shipping company by the consignee.); defects caused by normal wear of the product (expendable parts are typically connectors, cables, potentiometers, switches and similar components); damage or defects caused by abuse, neglect, accident, failure to connect or operate the unit in any way that does not comply with applicable technical or safety regulations, or improper repair, excessive heat or humidity, alteration or unreasonable use of the unit, causing cracks, broken cases/housings or parts; damage caused by leaking batteries; finish or appearance items; items damaged in shipment en route to Nady Systems, Inc. for repair. The warranty is null and void if any Nady serial number has been removed or defaced.

How To Obtain Service:

- 1) If factory service is required, you must contact our Service Department at (510) 652-2411 for a return authorization (R/A) number. Make sure the R/A number is clearly marked on the outside of your package. (Please note: if an R/A number is not included, our Shipping Department cannot accept your package.)
- 2) Send the unit back to Nady Systems, Inc., 6701 Shellmound Street, Emeryville, CA, 94608, freight pre-paid. You must include proof of date and place of purchase (i.e., photocopy of your bill of sale) or Nady cannot be responsible for repair or replacement. Nady Systems, Inc. will not repair, nor be held responsible, for any units returned without proper identification, return address, and RA number clearly marked on the package.
- 3) Per the above, Nady will perform all warranty service and return the unit to you at no charge. Nady Systems will inform the buyer if product sent in does not meet the terms of this warranty and will provide a quote for fixing the unit and/or shipping it back exclusively at the buyer's expense.



6701 Shellmound Street | Emeryville, CA USA 94608
T 510.652.2411 | **F** 510.652.5075 | www.nady.com